



Product Catalog

WINDOWS AND PATIO DOORS

LINCOLN
WINDOWS





With nearly 75 years of manufacturing experience and craftsmanship built into every window and patio door we produce, Lincoln continues to provide products with strong visual appeal and outstanding performance. A long history of satisfied homeowners is proof of our exceptional customer service before and after the sale.

We are continually expanding and refining our list of products, options and accessories to meet ever changing market needs. Our windows and patio doors are independently tested and certified to meet energy efficiency requirements and structural performance expectations. Also, in order to maintain the high level of quality you expect, we test products in-house against rigid industry manufacturing standards.

Whether your project is residential, light commercial or replacement, we are confident Lincoln has the products to meet your needs.



General Information

Markets 3
 Environmental Commitment 4

Exteriors

Aluminum Clad 5-6
 Vinyl Clad 7-8
 Hybrid 9-10
 Primed Wood 11-12
 Natural Wood 13-14

Options

Exteriors 15-18
 Interiors 19-20
 Lites & Grilles 21-22
 Glass 23-25
 Screens 26

Windows

Casement & Awning 27-32
 Double Hung 33-38
 Glider 39-40
 Specialty 41-44

Patio Doors

Swing 45-54
 Folding 55-56
 Slide 57-58
 Multi-Slide 59-60
 Lift & Slide 61-62

Series

Revitalize - Replacement 63-64





Residential

Every new residential project is the culmination of a persons' dreams. Product selection, from flooring to shingles, are all key elements to fulfillment of that dream. Lincoln windows and patio doors are made to compliment any architectural style in size, shape and color to help your dream become a reality.



Remodeling

Your home is where your heart is. Do a makeover on something you love! There has never been a better time to improve comfort levels, lower energy costs and increase market value. Our Revitalize Series includes remodeling products designed specifically for your next replacement window project.



Light Commercial

A school, library, office complex, country club, fire house, armory, hotel, assisted living facility, or condominium – one thing these examples all have in common is their Lincoln windows. Some are installed in new construction and some as renovations. Lincoln windows, beautiful as residential products, also meet the demands of light commercial applications.

The Environment

Our management team feels strongly about protecting and preserving the environment and we have implemented programs to reduce landfill waste and lower energy consumption.

We recycle: aluminum, anti-freeze, ballasts, batteries, cardboard, cellular PVC, copper wire, electronics, fluorescent light bulbs, freon, glass, oil, oil filters, paper, plastic bottles, sawdust, scrap metal, shrink wrap, soda cans, steel, tin, tires, vinyl and wood.



Energy Efficiency

Our products are tested and certified for water penetration, air infiltration, structural integrity and thermal performance. We also offer numerous product enhancements to increase energy savings such as thermal breaks, weatherstripping and high performance glass. In addition, we engage in lean and sustainable manufacturing processes and strive to use suppliers that do the same.



Testing and Certification

Our products carry certification by the National Fenestration Rating Council (NFRC). In addition, Lincoln is an ENERGY STAR Partner. One portion of a product's certification is derived from computerized simulation, which computes the thermal value of the product. Another is physical testing to establish air and water infiltration and structural performance. We strive for the best in our windows and doors.



Aluminum clad is definitely the most popular exterior choice from Lincoln, offering color flexibility and structural strength while providing a homeowner with a low maintenance exterior. Extruded aluminum .050 thick frame and sash cladding protects homes from the outdoor elements and add structural integrity for maximum functionality. The Aluminum Clad Collection is wide-ranging and includes a full line of windows, patio doors and a multitude of options.

Beauty, durability, variety and performance are all brought to you by the Aluminum Clad Collection and built with pride at Lincoln.

Features

- **Available Product:**
Full product selection.
- **Maintenance:**
Minimal. Periodic soap & water.
- **Structural Performance:**
Superior strength and rigidity for all-weather protection.
- **Thermal Performance:**
High. Good for meeting Energy Star.



Frame and Sash Finishes

We offer eight standard colors, thirty-eight feature colors, seven spray-on anodized colors and have the ability to match from a customer's sample.

All of our standard, feature and custom color options are painted to AAMA 2605 performance requirements. AAMA 2605 high performance paint is the preferred choice of designers, architects and builders. Exceptional color retention and minimal chalking are leading characteristics of this premium paint finish.

Standard Colors - AAMA 2605

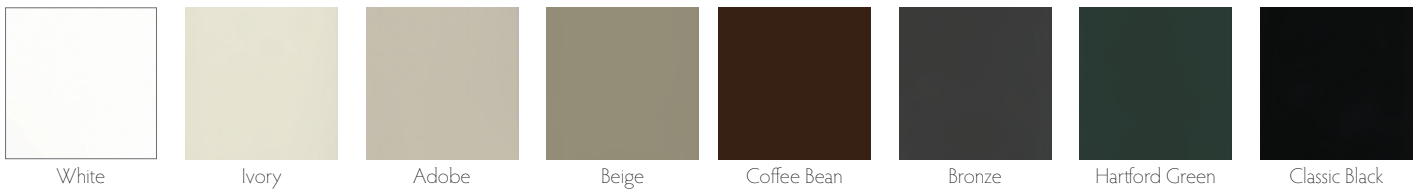

Feature Colors - AAMA 2605



Spray-On Anodized Colors - AAMA 2604

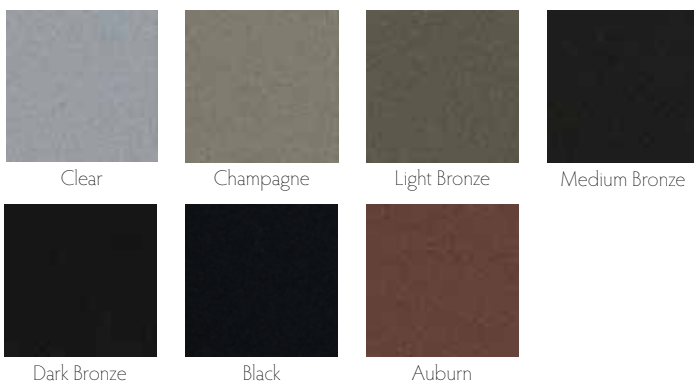

Custom Colors - AAMA 2605



Due to printing limitations, the colors shown are for representation only.

Our thought process behind the Vinyl Clad Collection is simple. Create an exceptional value-based window platform that performs well without sacrificing quality attributes like cladding thickness, amount of material and product enhancement choices.

Vinyl clad exteriors resist the harmful effects of salt water spray, UV damage and have excellent color retention making it a great choice for harsh environments.

Vinyl clad products have a high level of energy efficiency and superior exterior protection along with a multitude of available options.

Features

- **Available Product:**
Limited product selection.
- **Maintenance:**
Very minimal. Periodic soap and water.
- **Structural Performance:**
Excellent resistance to harsh coastal environments.
- **Thermal Performance:**
Very high.





Frame and Sash Finishes

Our vinyl clad product is offered in 2 extruded colors, White and Adobe. No sacrifices are made in the manufacturing of the Vinyl Clad line. In fact, many builder clients favor the traditional exterior appearance, excellent color steadfastness, value-based product pricing and exceptional energy performance, all backed with a strong Lincoln warranty.

Extruded Colors

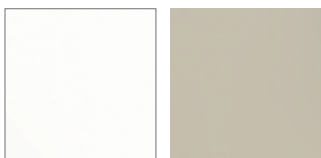

White

Adobe

The best of both worlds! Combine a traditional window look with today's modern exterior options. Create your hybrid window package by picking a traditional trim/casing and then choose an aluminum clad or vinyl clad sash. This unique blend of conventional window parts and popular accent trim best describes this collection.

Casings are non-rot cPVC and will take heat reflective and UV resistant paint well, allowing you to match our clad sash. For the more adventuresome, you can create a color contrast between the sash and frame. Historical appearances will charm an architectural eye and our durable low-maintenance qualities will satisfy an owners concern for longevity.

Features

- **Available Product:**
Extensive product selection.
- **Maintenance:**
Moderate. Apply UV resistant paint and periodic check-up.
- **Structural Performance:**
Excels in strength and design flexibility.
- **Thermal Performance:**
High.





Primed Frames

Wood with a white factory applied water-based acrylic latex primer and white, paintable cellular PVC sill, blindstop & casings.

- Five (5) standard exterior trim options: 2" Brickmould, Williamsburg Trim, Backband, 2-Piece Backband and Flat Casing (up to 8").
- Two (2) sill nosing options: 1" and 2"

Aluminum or Vinyl Clad Sash

Choose a low-maintenance sash option in either extruded aluminum or vinyl.

- Extruded Aluminum Clad Sash: Painted to AAMA 2605 performance requirements in 8 standard colors, 38 feature and custom colors. Also available in AAMA 2604 spray-on anodized in 7 finishes.
- Extruded Vinyl Clad Sash: Available in 2 extruded colors, White & Adobe.

This time-honored window design captures the original depth and beauty of Lincoln products. Our Primed Wood products are architect friendly and designed for new construction or historical renovation.

High risk rot-prone components are substituted with cPVC parts ready for a high quality heat reflective and UV resistant exterior paint color choice.

From a traditionalist point-of-view, Lincoln's stylish windows, patio doors and shapes are dimensionally accurate, historically desired and design friendly.

Features

- **Available Product:**
Extensive product selection.
- **Maintenance:**
Moderate. Apply UV resistant paint and periodic check-up.
- **Structural Performance:**
Exceptional strength.
- **Thermal Performance:**
Very high.





Frame Finishes

Wood with a white factory applied, water-based, acrylic primer and white, paintable cellular PVC sill, blindstop and casings or all-wood with a white factory applied water-based acrylic latex primer.



Sash Finish

Wood with a white factory applied, water-based acrylic latex primer.

Nothing demonstrates class better than the warmth and beauty of all natural wood. Lincoln's Natural Wood Collection clearly defines elegance and charm on both the exterior and interior of your home or business.

Wood is nature's exceptional natural insulator. Environmentally friendly wood is a very energy efficient window construction material and is a renewable resource.

Protect your investment by applying a quality stain and sealer on both window surfaces and enhance the appearance all while blending in with your native landscape.

Features

- **Available Product:**
Extensive product selection.
- **Maintenance:**
Frequent. Apply high-grade finish and inspect annually.
- **Structural Performance:**
Exceptional strength.
- **Thermal Performance:**
Very high.





Frame & Sash Finishes

High-grade natural wood inside and out in three beautiful species.



Fir

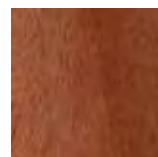

Mahogany



Pine

Trim

Add that finishing touch to the exterior of your windows and patio doors by adding one of the many brickmould and casings offered by Lincoln. Along with enriching the aesthetics of your home, these factory-applied trims reduce the installation labor and hassle.

For aluminum clad units, Lincoln offers extruded aluminum brickmould in 2" and 4" widths, Bullnose Casing and 4" flat casing, along with 3 different sill nosing options. All come factory applied and are available in all of our aluminum clad colors.

Also available - a factory applied rigid aluminum nailing flange and color matched drip cap. This .050 extruded option features mitered corners with supplied gaskets.



Rigid Aluminum Nailing Flange

Extruded Aluminum

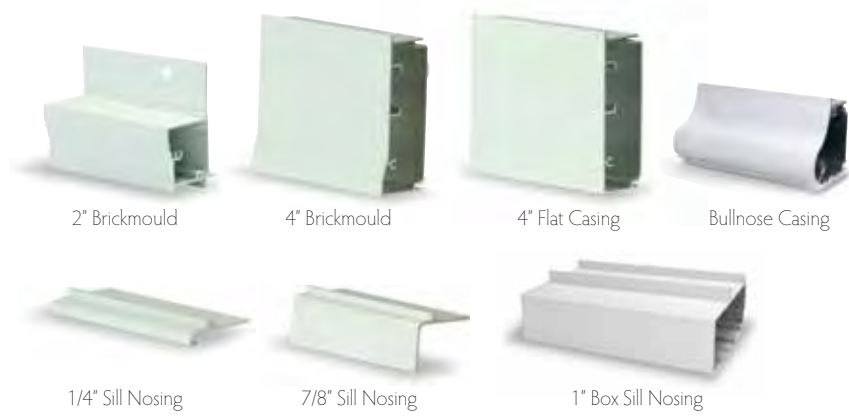

2" Brickmould

4" Brickmould

4" Flat Casing

Bullnose Casing

1/4" Sill Nosing

7/8" Sill Nosing

1" Box Sill Nosing

Note: 4" Brickmould & Flat Casings require installation clips.

The Lincoln vinyl clad windows feature an accessory groove to the exterior, just like our aluminum clad line, which will accept 2" brickmould, 3-1/2" flat casing and 7/8" Sill Nosing. These vinyl trims feature a 1" x 1" J-channel and integral nailing flange. The original window nailing fin remains fully intact strengthening the entire system. Architects will enjoy our attention to detail by providing an authentic sill profile.

Vinyl



2" Brickmould w/J-Channel

3-1/2" Flat Casing w/J-Channel

7/8" Sill Nosing w/J-Channel





The wood exterior product lines are available with cPVC 2" brickmould. Other styles of cPVC trim include Backband and Williamsburg along with flat casings up to 8" in width. When using heavier trims, the double hung & casement lines come with an optional 2" sill nosing for complimentary style. Primed and stain grade unfinished brickmould, sill and sill nosing are also available as options.



cPVC



Primed Wood



Natural Wood



Dressed up or dressed down, all windows and doors have trim. Lincoln offers trim variations for the convenience of the builder and the end user. Of course trim has a utilitarian function as a bridge between the window and the wall inside and out. However, trim ultimately frames the window in its setting. The exterior trim rounds out the architectural presentation. Interior trim becomes the frame for nature's setting.

Multiple Mull Options

- Tight and Spread Mulls

Panning

- Fills void between



Spread Mulls

When your project requires windows and patio doors in multiple-wide configurations, Lincoln has the mulls to make them right. Typical mulling is done with a tight unit to unit mull clip. Spread mulls add additional spacing between windows and patio doors. Popular reasons for utilizing a spread mull would include: accommodating a special opening with standard size windows, to achieve a 'heavier' look and the ability to work around essential structural framing. Spread mulls can be done both vertically and horizontally.

Extruded Aluminum

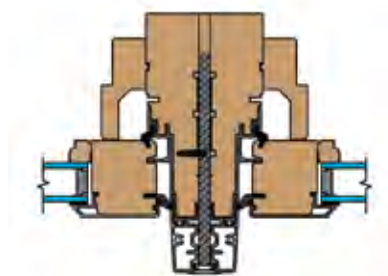
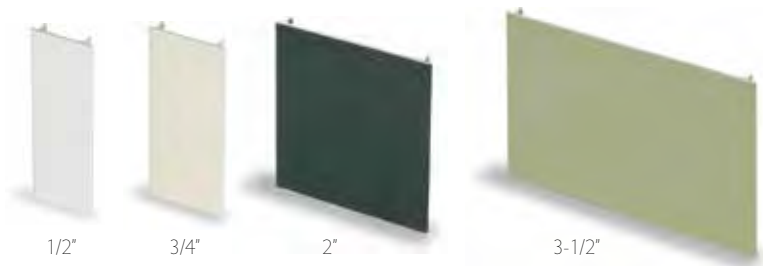

New - 1/4\" Extruded Aluminum Spread Mull with 1/4\" Steel Reinforcement

Vinyl





Panning Systems

Lincoln also offers a panning system for aluminum clad exteriors. These additional trims snap into the accessory groove which can add additional width and height to the exterior appearance of a window or patio door. This system will fill space from a window frame to the building thereby covering the framing material and nail fins. Incorporate an H-Clip and create an adjustable panning used to join two units fairly far apart. The panning system is a nice feature commonly used for remodeling when there are existing and varying openings.

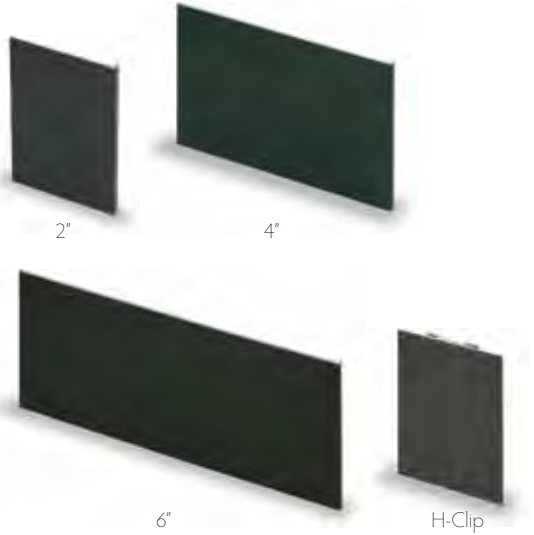



Finishes

Define inner beauty by choosing a time saving, factory applied interior finish from Lincoln.

Natural Wood: Lincoln will leave your interior wood surface sanded smooth, ready for stain and sealer.

Primed: If you plan to paint the interior of your windows and patio doors, have them primed with a white factory applied, water-based acrylic latex primer.

Pre-Finish Options: To take things a step further, we offer factory applied top-coats of paint intended to be your final coat of paint with the nail holes filled reducing jobsite finishing costs. Choose from our traditional Pre-Finish White or contemporary Pre-Finish Black.



Primed



Pre-Finish White



Pre-Finish Black

Wood Species

Nothing enhances the look and feel of a room more than the richness and beauty of wood. Lincoln product comes standard with a pine interior which has a nice smooth finish ideal for accepting paint and stain alike.



Pine

For those looking to really enhance the character of a project, Lincoln also offers six additional wood species. The popular red oak, white oak, cherry, alder, mahogany and fir options all come with their own unique color and grain patterns to really enhance the character of the window.



Alder

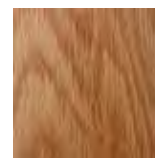

Red Oak



White Oak



Cherry



Mahogany



Fir

Jamb Extensions

When installing a window, increasing the depth of the window frame to accommodate the wall thickness is sometimes necessary. This can easily be accomplished with the use of jamb extensions. These factory applied extensions are available in all seven wood species.



Trim

Lincoln offers interior trims in ten profiles for radius products. Customers benefit from our ability to shape the trim at the time a unit is produced.

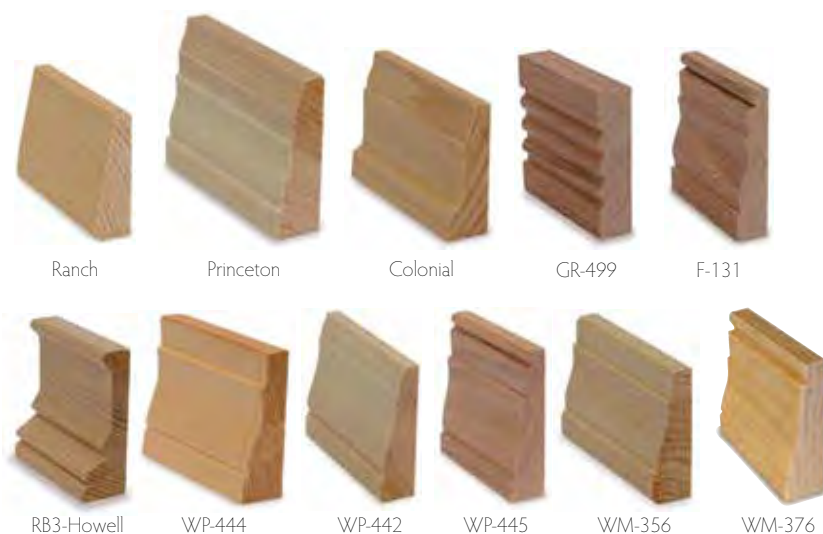

Here is another opportunity to have your windows and doors made to fit the interior design, décor and style of the room. Additionally, the exterior interacts with the overall architecture and creates fantastic curb appeal. Enhancing windows and doors with lite divisions definitely puts the icing on the cake. Although there are standard lite configurations designated for all products, custom designs are also welcome.

Lite & Grille Options

- Simulated Divided Lite (SDL)
- Interior Wood Grille
- Internal Aluminum Grille (GBG)
- Lincoln Divided Lite (LDL)



Simulated Divided Lite

- 5/8", 7/8", 1 1/8" and 2"
- Profiled or Square
- Bronze, Black & Mill Finish Shadow Bar



Simulated Divided Lite

Interior Wood Grille

- Single Profile Widths: 5/8", 1", 1 1/8" and 1 1/4"
- Double Profile Width: 7/8"
- With Surround
- Without Surround



Interior Wood Grille (With Surround)



Internal Aluminum Grille

- 1 1/8" Double Profiled
- Color Matched to Cladding
- Two-Toned (white one side, 9 standard colors on other side)



Internal Aluminum Grille

Lincoln Divided Lite

- 7/8" and 1 1/4"
- Authentic Divided Lites
- True Historic Appeal



Lincoln Divided Lite
(Primed only)

The glass in windows and patio doors has the single largest effect on energy efficiency. Lincoln's standard insulated glass offering includes double strength glass combined with a warm edge spacer. For greater energy efficiency, argon is added to all Low-E glass units, at no cost to the customer, with the exception of those units requiring capillary/breather tubes.* Choose Lincoln's standard glass or a combination of the options for appearance, performance and comfort.

* These are units shipped over high elevations. Lincoln does not guarantee that the initial argon fill rate will be maintained over the life of the product. Argon depletion may decrease energy efficiency. For more information, contact your local distributor or Lincoln Wood Products, Inc.

Insulated Glass Construction

Our insulating glass (IG) is constructed with four major components. It's the quality of these components, sheet glass, desiccant material, sealants and spacers that set companies apart.

Let's consider the sheet glass. We exclusively utilize double-strength glass (3.2mm) even on the smallest sizes. Some companies believe this should be an upgrade while we eliminated the thinner glass option many years ago.

Quality desiccant material is used to absorb moisture within the IG unit during assembly and the polyisobutylene sealant provides excellent adhesion to the glass with a low moisture vapor transmission rate for years of outstanding field performance.

Choose one of our premium warm-edge spacer systems to complete your perfect glazing package.



WARM EDGE SPACER

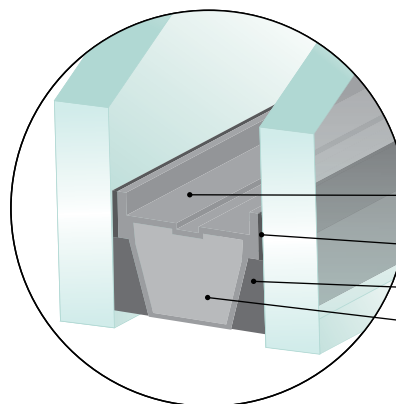

Endur IG Spacer

1. Stainless steel spacer available in mill finish, bronze, black or white.
2. "Polyisobutylene" primary seal.
3. Specially formulated secondary seal.
4. Desiccant material.

LoE-180™

Constructed with a single LoE coating, this glass option is perfect for climates where solar heat gain is welcome. LoE-180™ outperforms clear IG glazing with warmer inside glass temperatures and better UV protection.

Projects looking for passive solar glazing solutions including good U-Value performance in conjunction with higher Solar Heat Gain Coefficients experience positive benefits with LoE-180™.

LoE²-272®

Safeguard your home from the elements by using this nearly invisible protection. Consisting of two microscopic layers of silver sealed in the airspace, this glass is a nice step-up from our standard offering.

Obtain an affordable balance of U-value, solar shading, visible light transmittance and UV protection by choosing LoE²-272®.

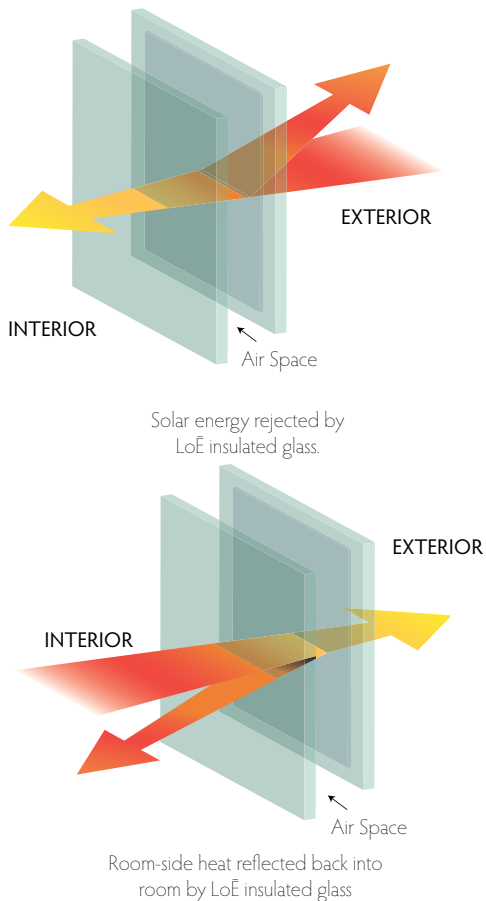

LoE³-366™/Neat®

Controlling solar heat gain just became easier with the unparalleled performance of LoE³-366™/Neat® glass technology. By adding a third layer of silver coating, LoE³-366™/Neat® effectively blocks solar gain and reflects heat more efficiently.

In addition to reducing heat gain, the goal with any high performance glazing is clarity. LoE³-366™/Neat® was produced to show a minimum of exterior "mirror" reflectance and does not require smoke-colored tints that can darken your home's interior.

Dual Low-E2 (LoE i89™/LoE²-272®) and Dual Low-E3 (LoE i89™/LoE³-366®)

Our most ecologically aware combination of glass products designed for projects requiring extraordinary energy efficiencies.

As the ENERGY STAR® program ratchets up its requirements, our glass offering continues to provide consumers with an ability to comply. Lincoln's Dual Low-E options are the next generation insulating glass packages that tackles these stricter requirements by combining LoE²-272® or LoE³-366® with a room side LoE coating (LoE-i89™ is on surface #4). Don't worry, LoE-i89™ performs well without sacrificing glass clarity, doesn't require special cleaning and provides additional UV protection.

This energy efficient glass lowers U-Values and retains more of your costly heat inside for the Northern and North/Central zones. Assembling Dual Low-E with our foam spacer system further improves U-value performance.

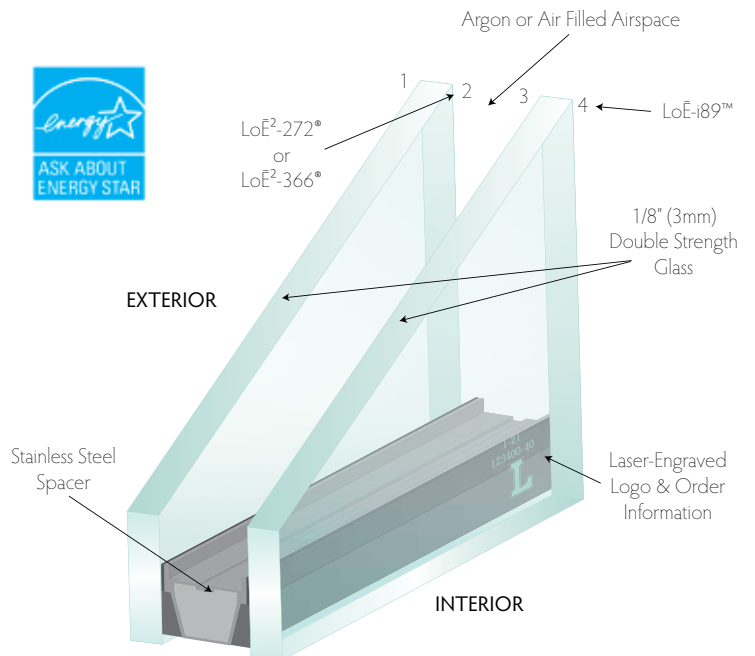

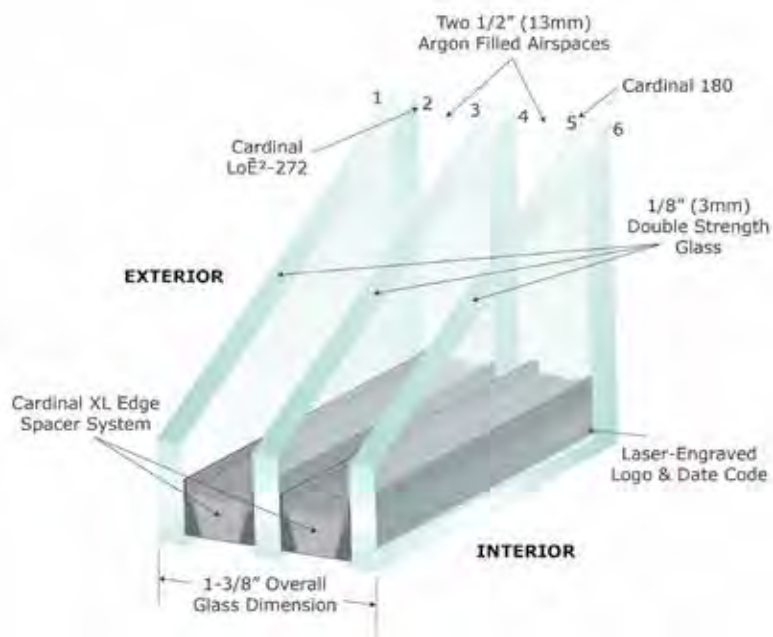

Triple Pane Glass

Experience excellent thermal comfort with Lincoln's most energy conscious glazing selection-Triple Pane Glass. This glass offering utilizes 3 sheets of double strength glass, Cardinal's Endur IG spacers and features an Argon Gas fill. Triple Pane glass is perfect for your new energy efficient home.

Clients enjoy reduced condensation during freezing cold weather, better UV protection and improved Sound Transmission Class (STC) ratings by including Triple Pane glass.

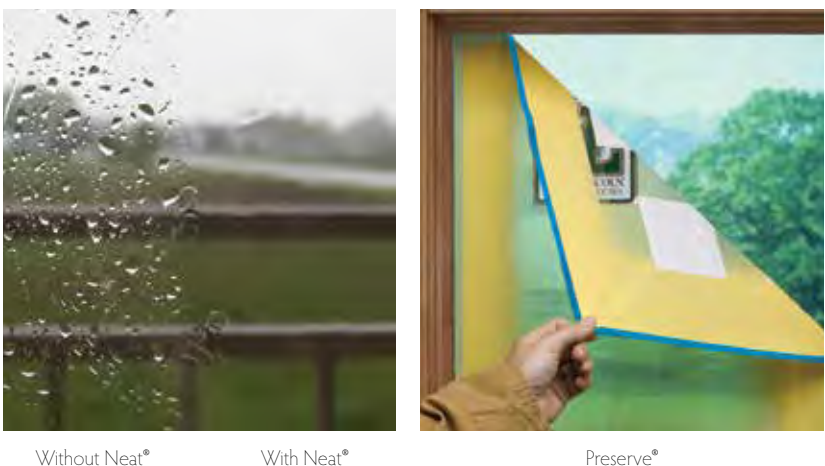

Neat® and Preserve®

Neat®: Combines a permanent layer of silicon dioxide, which causes water to sheet off leaving fewer water spots, and a layer of titanium dioxide that reacts with the sun's UV rays causing organic material on the glass to decompose - no manual activation required.

Preserve®: A low density polyethylene adhesive that protects the glass during shipping and construction making clean-up a quick and easy process.

Specialty Glass Options

The majority of projects utilize clear glass, but occasionally a project requires the use of a specialty glass. Whether it be to conceal the view from the exterior of a building, distort the details of objects through the glass or provide an extra level of safety, we have a variety of specialty glasses that will meet your needs. Our specialty glass options include: laminated, obscure, tempered, tinted and spandrel.

Obscure Patterns

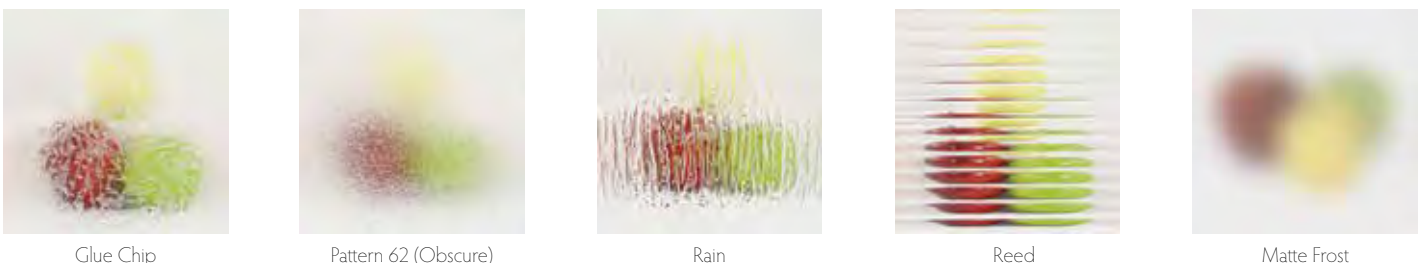

Tinted Glass

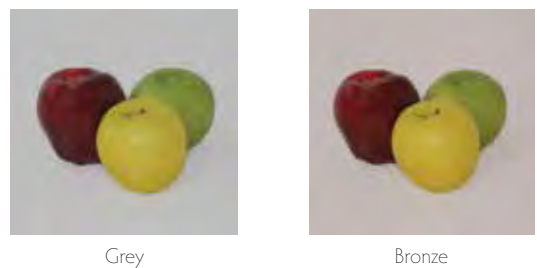

Screen Mesh

Screens allow you to enjoy the fresh air while keeping insects and debris out of your home. Lincoln offers three practical options.

BetterVue: Our standard screen mesh. Made of fiberglass, it has thinner strands and a tighter weave than traditional fiberglass screen providing better visibility, increased light transmittance, greater airflow, improved curb appeal and enhanced protection from small insects (no-see-ums), debris and dust.

UltraVue: The least visible of our screen mesh options. The strands of UltraVue are thinner than BetterVue, providing even better airflow, optical clarity and insect protection.

Aluminum (charcoal wire): The most widely used metal for screens and is a great option for homes with pets or kids.

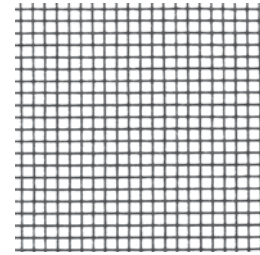

BetterVue

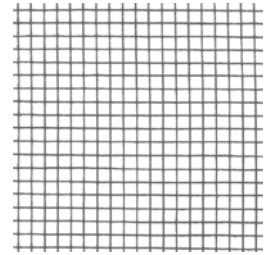

UltraVue

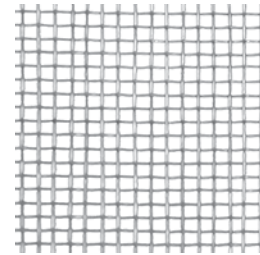

Aluminum

Screen Finishes

Lincoln interior screens are available in five metal frame finishes. Our color-matched PVC corner keys help keep interiors from scuffing during removal and installation. Double Hungs, Gliders and Patio Doors feature color-matched screen frames to match the exterior.

Standard Colors



White



Coppertone



Bronze

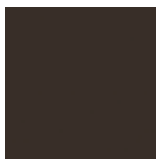

Faux Bronze



Black



Available as a traditional cranking unit or as our increasingly popular push-out style, Lincoln casements and awnings have a lot to offer.

Casement and awning features include an architecturally pleasing recessed sash, mortise and tenon joinery, multi-point locking hardware with single handle activation and adjustable hinges.

Awnings can be mulled above or below a studio window or utilized as a standalone element. Because they are hinged at the top, awnings provide secure ventilation and shed water during a light rain.

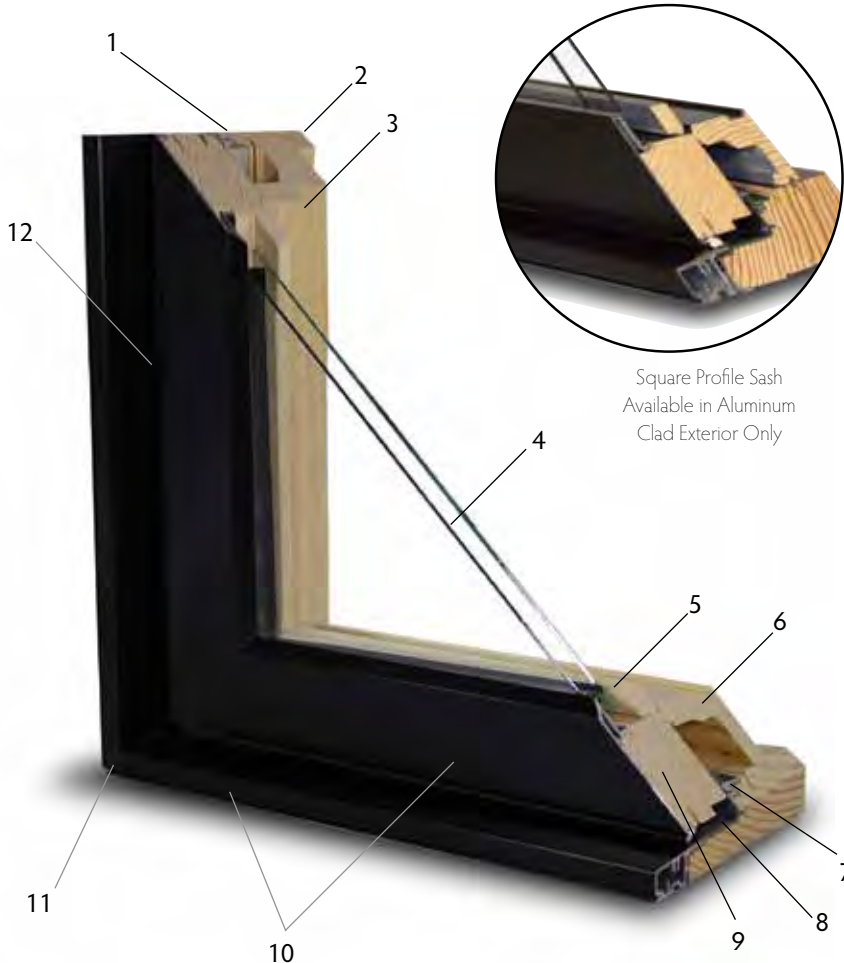

Square Profile Sash
Available in Aluminum
Clad Exterior Only

Specifications

Specifications	
Maximum RO Width	42 ½"
Maximum RO Height	96 ½"
Sash Thickness	1 ¾" thick

1-3/4" Sash

1. 4-9/16" jamb.
2. 1-3/16" thick side jambs, head and sill.
3. Clean interior stop design.
4. 7/8" warm edge insulating glass.
5. Interior wood glazing bead.
6. Maximum thickness sill cover.
7. Full surround frame weatherstrip.
8. Thermally enhanced frame with specialty composite polymer.
9. 1-3/4" thick sash.
10. .050 extruded aluminum on sash and frame. Vinyl exteriors utilize .050 extruded PVC vinyl. Wood units have primed sash on the exterior with cPVC, sill nosing and brickmould.
11. Gasketed frame corners on aluminum clad products with corner key for added stability.
12. Sash weatherstrip with combination drip cap detail on top rail.

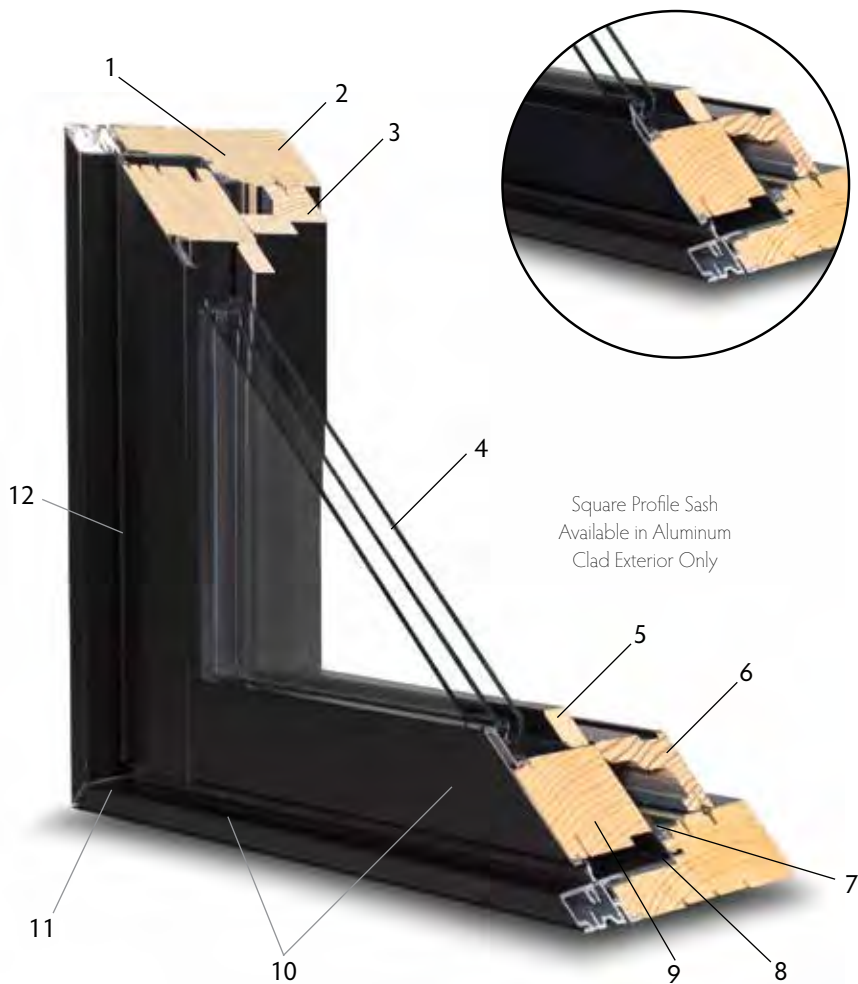

Specifications

Maximum RO Width	36 1/2"
Maximum RO Height	84 1/2"
Sash Thickness	2 1/4" thick

2-1/4" Sash - Triple Pane

1. 4-9/16" jamb.
2. 1-3/16" thick side jambs, head and sill.
3. Clean interior stop design.
4. 1-1/4" triple glazed warm edge insulating glass.
5. Interior wood glazing bead.
6. Maximum thickness sill cover.
7. Full surround frame weatherstrip.
8. Thermally enhanced frame with specialty composite polymer.
9. 2-1/4" thick sash.
10. .050 extruded aluminum on sash and frame. Vinyl exteriors utilize .050 extruded PVC vinyl. Wood units have primed sash on the exterior with cPVC, sill nosing and brickmould.
11. Gasketed frame corners on aluminum clad products with corner key for added stability.
12. Sash weatherstrip with combination drip cap detail on top rail.

Hardware

Casement & Awning: Lincoln products feature a low profile folding handle, advantageous for use with some window treatments and provide lower clearance for removal of window screen. As standard, operating hardware (crank handle, operator cover and lever lock) are a soft coppertone color that blends well with most clear wood finishes. All casements feature adjustable hinge tracks for proper sash alignment.

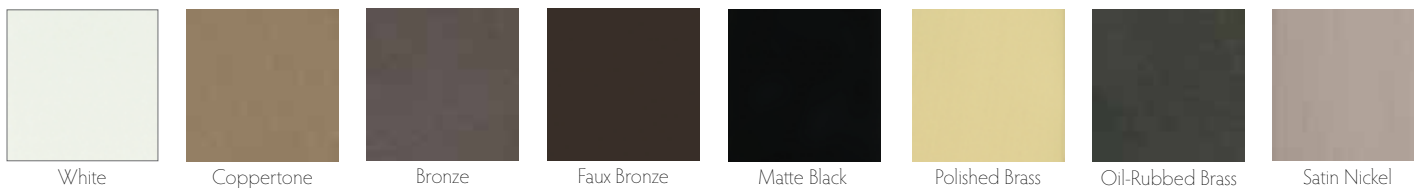

Contempo casement hardware: Contemporary enthusiasts utilize the Contempo gear cover and handle as the finishing touch to a clean crisp design aesthetic. Cover and handle are metal, have a durable finish yet are an affordable upgrade. This style fits all Lincoln crank out casement and awning windows.



Standard Finishes

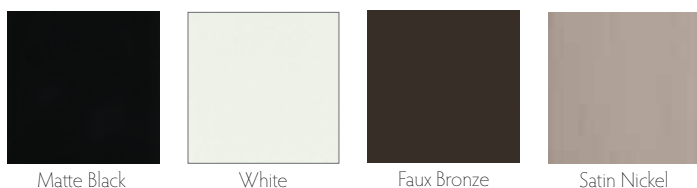

Special Order Finishes*

*May require additional lead time.



Push-Out Casement & Awning: Single handle for easy operation and available in five finishes: Faux Bronze, Polished Brass, Black, White and Satin Nickel. Multi-point locking system directly routed into the stile for greater performance, security and durability.

3-point stainless steel high-friction washability hinges on top and bottom keep the window in place and allow access to clean the glass from the inside.





Screens

Standard: Casement & Awning windows come standard with 5 metal frame finishes to compliment hardware.

Retractable: Available on our traditional casement and our push-out style casement, retractable screens roll up for convenient storage when not desired. Screens are operated with a simple touch and roll up with very little effort. Enjoy crisp clean interior lines because operating tracks are hidden with a wood cover.

Hinged: Designed for our push-out style casement products, Lincoln's hinged screen offers classic styling and excellent functionality. This screen option is supplied with an attractive color-matched knob for easy operation.

Sash Limiters: Thinking safety? Lincoln offers safe and secure sash limiters. This release mechanism keeps the window from being opened no more than four inches, allows the window to be fully opened for quick emergency exits and resets automatically every time the window is opened - all meeting the requirements of ASTM F2090.



Retractable Screen



Hinged Screen





Styles

Casement: The Lincoln crank-out casement is a versatile design with exceptional architectural appeal, performance and strength. Available in many combinations of types and sizes, our casement line delivers outstanding value without sacrificing or limiting product options.

Stylish Truth brand operators function smoothly while opening the sash to a full 90° for maximum ventilation. Single-lever multipoint sash locks pull tight to a full perimeter weatherstrip for security against the elements. Heavy frames and sash components are standard.



Radius Top Casement: Lincoln casements with a radius design element are sure to add elegance and charm to any building project. Segment head casements and our traditional casements have matching sight lines so they can cosmetically complement each other.

Segment head operating windows combined with stationary units and studio picture windows create many design options. Exterior (outboard) hinges allow for easy operation. Radius interior trim is available for the finishing touch.



Push-Out French Casement: Continental flavor is apparent in Push-out French casement windows –one window frame – two operating sash – one clear opening. Push-out French casements are available in standard twin casement widths for perfect vertical sight line presentations when used in combination with standard casement windows.

Their popularity is additionally increased due to egress code requirements for width. Operation, via the centrally located lever activates a multi-point system that functions easily and locks securely.

Awning: As part of Lincoln's casement family, traditional crank-out awning windows look great and perform efficiently year-after-year. Awnings match casement/studio profiles, are stackable and can be mulled above (as a transom) or below in multiple combinations.

Awning characteristics allow venting from the bottom and will shed light rain. Sash locks, located on the side jambs, pull sash tight to the frame weatherstripping and make traditional awning units very secure against turbulent weather.



Push-Out Casement and Awning: These windows are beautiful inside and out. The sash swings open with a simple turn of the handle, while the friction hinges keep it firmly in place whether fully or partially opened.

Traditional hinged screens add a historical touch-of-class and feature a color matched knob. Or, choose a retractable screen that rolls up when not needed, leaving a clear view of the outdoors.



Casement Bay and Bow: Casement bay and bow units offer contemporary styling, create a roomy feeling, increase ventilation and can be built in many combinations.

Bay units are constructed using three windows or more. Flankers are aligned with a center unit at 45° or 30° angles.

Bow windows typically feature a series of 3-6 casements mulled as a radius.

Bay/Bow windows may include factory-assembled head and seat boards and a cable kit to compensate for overhanging weight and aid in installation.



DOUBLE HUNG WINDOWS

Double hung windows are popular due to their traditional design that compliments so many different styles of homes. They're also easy to operate, maintain and clean.

Lincoln double hungs allow architects, designers and builders to customize and tailor each individual project. Your specialist will create a contemporary edge with the clean lines of our narrow rail sash. Or stick with a strong historical influence by utilizing our traditional wide rail sash. Double hungs offer the flexibility to accommodate many design elements and are a great choice for both residential or light commercial projects.

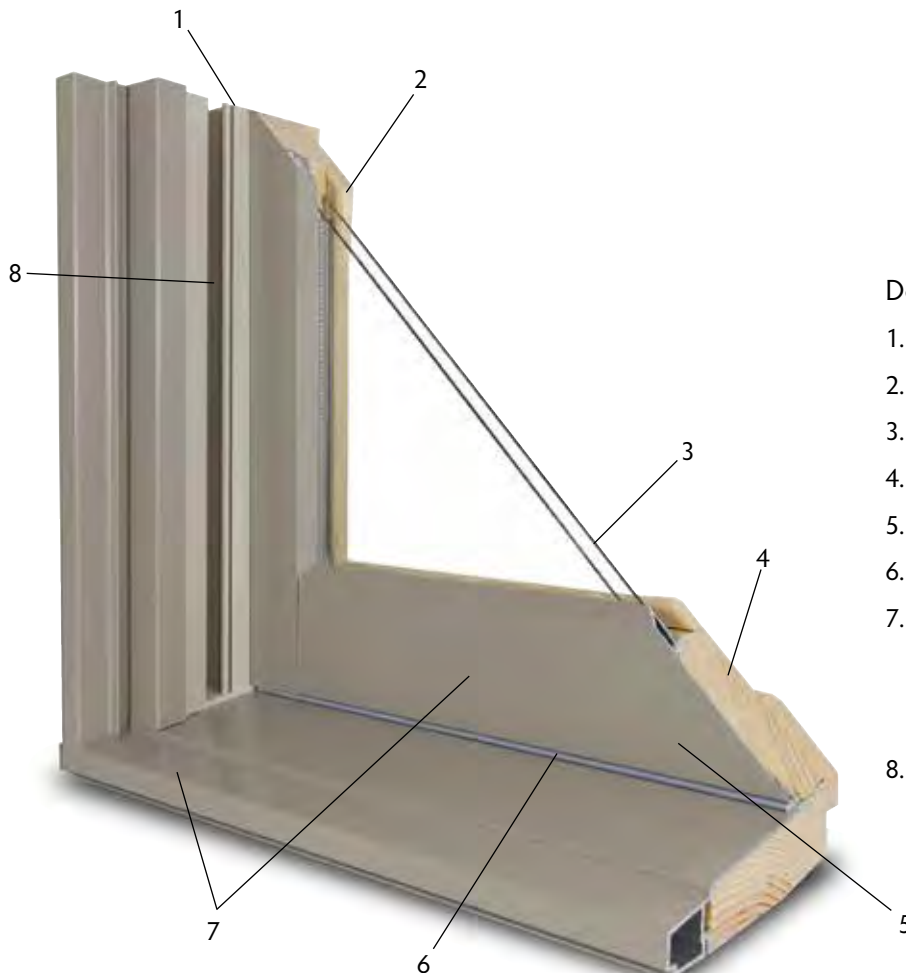

Specifications	
Maximum RO Width	45 3/8"
Maximum RO Height	93"
Sash Thickness	1 7/16" thick
Bottom Rail Height	2 1/16"

Double Hung with Wide Rail Sash

1. Full 4-9/16" jamb depth.
2. Interior wood glazing bead.
3. 1 1/16" warm edge insulating glass.
4. 1-7/16" thick sash.
5. Traditional wide rail sash profile option.
6. Weatherstripped at head, sill and checkrail.
7. .050 extruded aluminum on sash and frame. Vinyl exteriors utilize .050 extruded PVC vinyl. Wood units have primed sash on the exterior with cPVC sill, sill nosing, blindstops and brickmould.
8. Recessed jambliner option with inverted balance system.

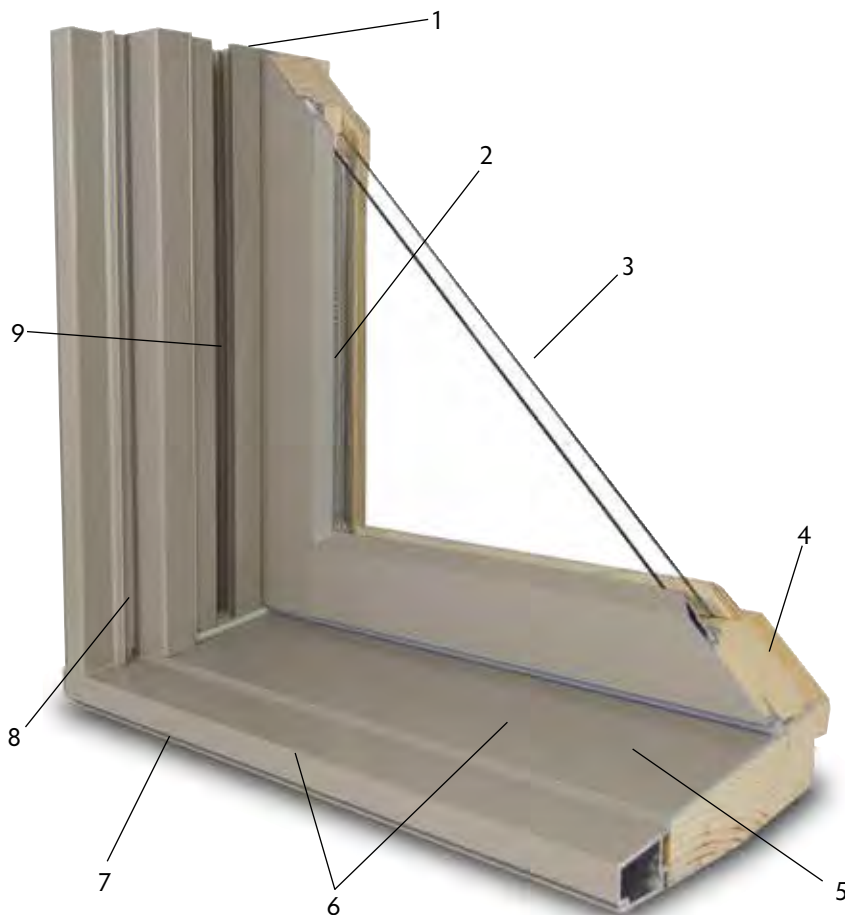

Specifications

Maximum RO Width	45 3/8"
Maximum RO Height	93"
Sash Thickness	1 7/8" thick
Bottom Rail Height	1 1/8"

Double Hung with Narrow Rail Sash

1. Full 4-9/16" jamb depth.
2. Sloped putty-glazed styling.
3. 11/16" warm edge insulating glass.
4. Contemporary narrow rail sash profile option.
5. Low-profile 8° sloped sill.
6. .050 extruded aluminum on sash and frame. Vinyl exteriors utilize .050 extruded PVC vinyl. Wood units have primed sash on the exterior with optional cPVC sill, brickmould and blindstop.
7. Full perimeter accessory groove.
8. Integral screen channel.
9. Concealed jambliner option with inverted balance system.



Hardware

Locks & Tilt Latches: Available in seven hardware finishes, two low-profile pick resistant locks are used on units with 37 3/8" box size and wider. Units smaller than 37 3/8" box size have one lock.

Color matched double hung tilt latches are set into the check rail of the bottom sash and concealed in the top rail on the upper sash. Spring loaded, they release to tilt in with ease. Made to last and out of sight, these lock options are sure to please.



Sash Lift/Pull Handles: Our stylish lift/pull handles are available in three popular finishes that match sash locking hardware. They are also very easy-to-grab and easy to install after the interior finishing process is complete. These handles reduce damage from opening your windows by providing a solid area to grasp.

Not available for narrow rail double hung

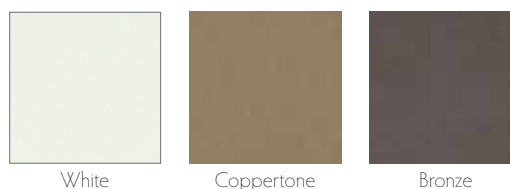

Sash Limiters: Thinking safety? Lincoln offers safe and secure sash limiters. This release mechanism keeps the window from being opened no more than four inches, allows the window to be fully opened for quick emergency exits and resets automatically every time the window is opened - all meeting the requirements of ASTM F2090.

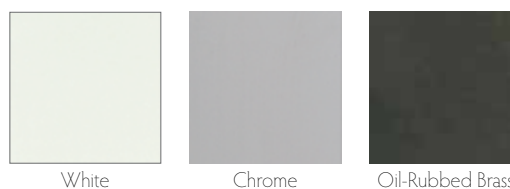



Jambliner Options

Lincoln offers two different jambliner options for our double hung window lines. Both options utilize an inverted balance system for consistent performance and durability.

The standard jambliner comes in either beige or white and is recessed in the frame to minimize its visibility.

The concealed jambliner takes the design aesthetic a step further. From the exterior, the jambliner is concealed by color matched cladding. From the interior, the jambliner design utilizes a clear pine insert to give more wood warmth when the window is closed.



Standard Jambliner - White Balances
Exterior View



Standard Jambliner - White Balances
Interior View



Concealed Jambliner - Beige Balances
Exterior View



Concealed Jambliner - Beige Balances
Interior View



Styles

Double Hung: This arrangement is an ageless window type that offers some unique advantages. Sash tilt in for easy cleaning, ventilation is improved by opening the top and bottom sash equally and classic historical appeal is achieved when using Lincoln double hungs.

Our traditional window is equipped with advanced energy saving features. For example, Lincoln double hung checkrails incorporate the use of interlocks, weatherstrip and high-quality sash locks for a precision fit.



Radius Top Double Hung: Built as a single hung, Lincoln segment head and quarter segment windows are part of our double hung family. By utilizing the same parts and simply fixing the top sash, radius top hung windows can be mixed with traditional double hungs to create exciting elevations.

As with all Lincoln radius shapes, interior trim is available for the finishing touch. Segment head windows include a half screen.



Double Hung Bay: What could be more exciting than installing a Lincoln double hung bay window at the heart of your room? This attractive window combination is sure to add both functionality and flair.

Bay units are constructed using three windows or more. Flankers are aligned with a center unit at 45° or 30° angles. Center units can consist of operating double hungs or studio windows.

Double hung bay windows may include factory-assembled head and seat boards and a cable kit to compensate for overhanging weight and aid in installation.



Searching for a really big window? The Lincoln Quantum double hung is the answer. Patterned after huge double hung windows typically found in older public buildings, the Quantum establishes its' value in both new traditional construction and the renovation of existing historical buildings. Quantum double hung windows are also available in a replacement kit package for replacement of existing over-size windows.

Not available in Vinyl Clad exterior.

Quantum Double Hung

1. 5-7/16" jamb.
2. 1-3/4" thick sash.
3. 7/8" warm edge insulating glass.
4. Interior glazing bead.
5. Historical 3-1/4" bottom rail.
6. 1-7/32" thick sill with 14° sill angle.
7. Mortise and tenon sash with putty-glazed style.
8. .050 extruded aluminum on sash and frame. Wood units have primed sash on the exterior with wood sill nosing and cPVC sill, blindstops and brickmould.
9. Heavy foam-backed PVC jambliners with four block and tackle balances per sash.

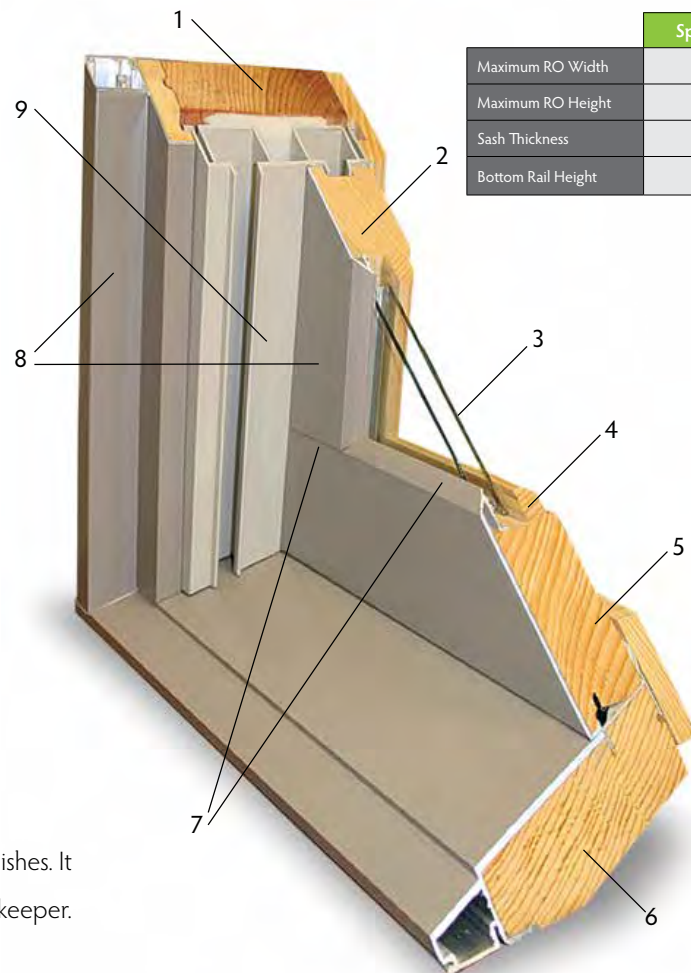

Specifications	
Maximum RO Width	56 3/8"
Maximum RO Height	114 7/8"
Sash Thickness	1 3/4" thick
Bottom Rail Height	3 1/4"

Hardware

Window Locks: Quantum sash locks are available in four finishes. It is a heavy-duty lock with alignment nubs that inset into the keeper. Typical Quantum double hung units have two locks.



GLIDER WINDOWS

Lincoln gliders are available as a single unit with one side fixed and the other operable or as a triple unit with operating sash flanking a studio center. Left or right handing for single units is specified at the time of order. Sash glide smoothly and evenly over a vinyl track for long-lasting trouble-free operation.

Also choose from a full or half screen option, eight hardware finishes, an array of exterior types and different interior wood species.

Not available in Vinyl Clad exterior.

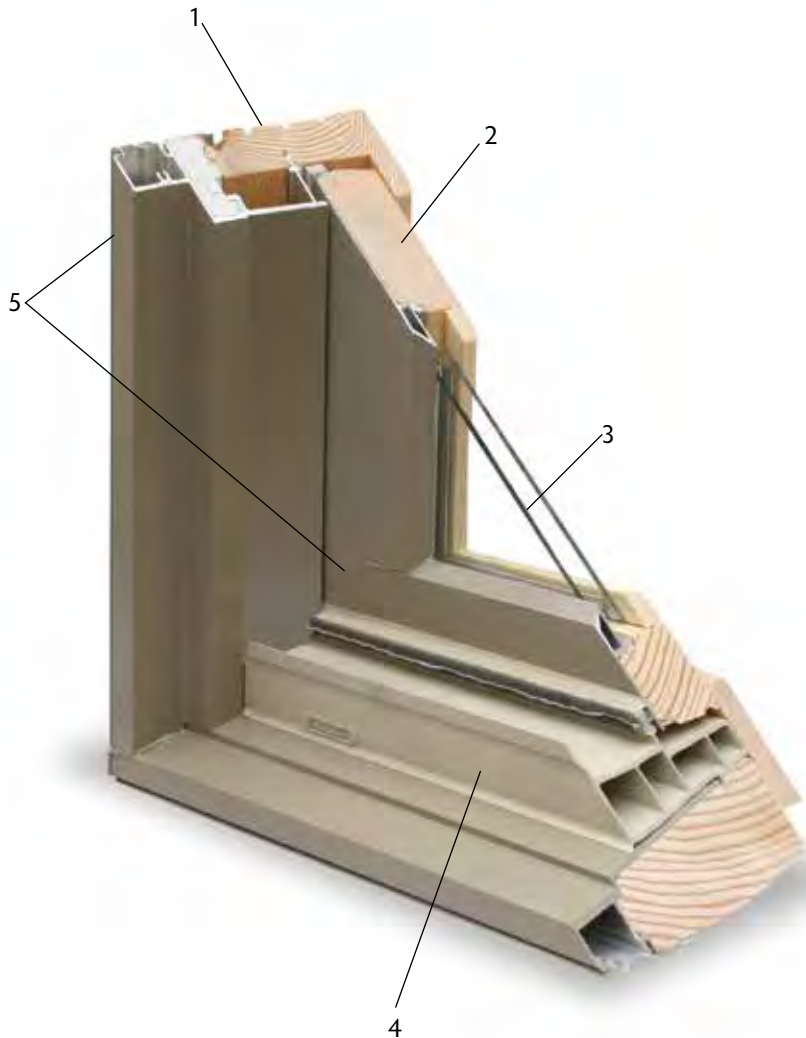

Glider

1. 4-9/16" jamb.
2. 1-7/16" thick sash.
3. 11/16" warm edge insulating glass.
4. Heavy extruded PVC sill track.
5. .050 extruded aluminum on sash and frame. Wood units have primed sash on the exterior with cPVC sill, sill nosing, blindstops and brickmould.

Styles

Glider: The gliders' main characteristic is its ability to slide easily on a heavy vinyl track. Lincoln gliders are the perfect utility window because they blend well with a twin casement from afar and are an exceptional value.

Our traditional glider is equipped with advanced energy saving features. For example, glider checkrails incorporate the use of interlocking sash, weatherstrip and high-quality locks for a precision fit.



Triple Glider: Lincoln's energy efficient triple glider is built to fill large openings and can be installed where casement windows, that open outward, are just not practical. Triple gliders operate from each end for excellent ventilation and utilize a studio center to capture your view.

Glider offer simple operation and are extremely durable because they have fewer moving parts. Triple gliders also reduce your energy consumption by featuring fully weather-stripped sash with interlocking checkrails.



Hardware

Locks & Tilt Latches: Available in seven hardware finishes, two low-profile pick resistant locks are used on units with 32" glass and taller. Units smaller than 32" tall have one lock.

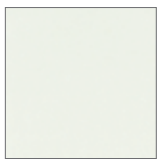

White



Coppertone

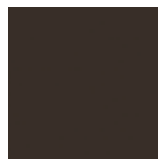

Faux Bronze



Black

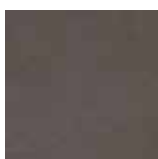

Bronze



Satin Nickel



Polished Brass

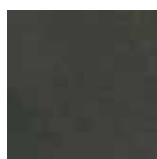

Oil-Rubbed Brass



Modern architecture often includes higher sidewalls and open spaces. Filling a wall with glass has never been easier - we have just the right sizes and shapes.

Lincoln offers rectangular & geometric units as well as radius products together totaling 20 different designs. Specialty windows can be complementary to our standard product or complete stand-alone windows.

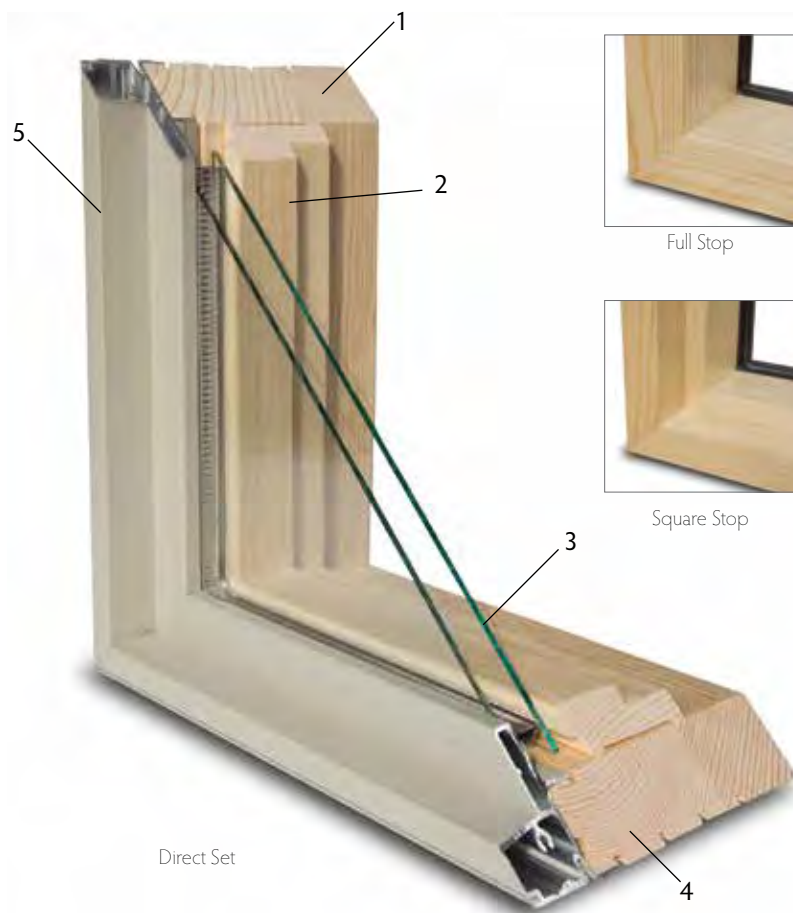

Full Stop



Square Stop



Radius Sash Set
(Shown with brickmould)

1. 4-9/16" jamb.
2. Interior wood glazing stop options.
3. 3/4" warm edge insulating glass. with 1 3/8" triple pane optional.
4. 1" thick frame.
5. .050 extruded aluminum frame. Vinyl exteriors utilize .050 extruded PVC vinyl. Wood units have primed frame exterior with cPVC brickmould and glazing stop.

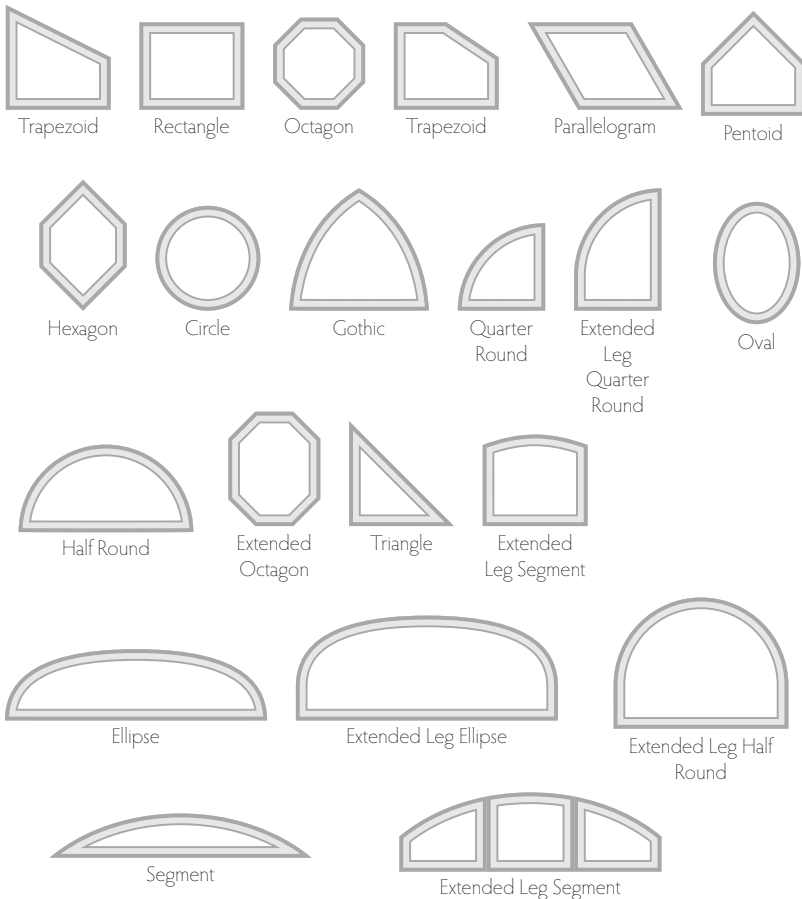

Styles

Shaped Windows: Be exciting, distinctive and even a little daring by incorporating a specialty window into your next project! Choose an elegant shape as the focal point of your elevation or as an accent in a foyer or gable. Let Lincoln's specialty department work for you!

Lincoln specialty shapes are crafted from a CAD template and built as a direct set frame or a sash and frame style. Radius shaped interior trim is available in ten different profiles, providing superb fit and finish.



Direct Set: A direct set shape is best described by installing a piece of insulated glass 'directly' into its frame. This is the most cost effective means to purchasing a non-operating window. Lincoln direct set windows can be built in every shape we offer including radius products and geometric shapes.

Direct sets are custom-sized windows and can include: multiple grille types, three glazing stop options, six wood species, applied jamb extensions, interior prime or pre-finish, all glass options and nearly any paint color.

Recent design trends led us to a contemporary style square stop profile - available on all direct set products.



Sash Set: A sash set Lincoln window employs a heavier look by adding a sash component within a frame (glass is glazed into a sash which is then installed into a frame). This design complements our operating units and is commonly used in combinations because glass sightlines match better.

Architecturally, a sash set is usually favored for its enhanced aesthetics. This type of window construction is both appealing and functional. View our options section for additional features such as: exterior trims, grilles, interior casings, colors and our many glass choices.



Studio Windows: The studio window is designed to compliment an operating unit as a muller combination or they can stand alone. Because studios are often fairly large windows, they add a sense of openness to a room and often times are positioned for a great view of the outdoors.

Lincoln constructs fixed studio windows as a direct set or in a sash and frame design. This is a perfect unit for commercial projects when venting is not required or the window is inconvenient to reach. Non-operable windows are also very energy efficient.

Transoms: With taller ceiling heights and the popularity of great rooms, you need your windows and patio doors to look and feel in proportion to the design. You can always go with a taller window or door, but transoms offer an exceptional design opportunity. Not only do you get the benefit of more light, you add a key architectural element to your room.

Transoms may be split to align with the window or patio door configuration or can be a one-piece design that extends over the entire span. Our transoms are made to exacting standards and can be built with narrow and wide stiles to maintain site lines. When looking for a little extra style or flair, transoms are a simple and attractive solution for your taller window and patio door requirements.



Corner Windows: From the outside, corner windows help break up the visual mass of a home and provide unique architectural appeal. From the interior, they provide a way to emphasize an incredible view or landscape while allowing sunlight to come in the room from separate directions throughout the day.

The Lincoln corner window is available up to a maximum 96" box width on one side and 72" box width on the other. Maximum box height is 96" with the overall square foot of glass size to not exceed 50 square feet per side.

The specialized center mull post is the significant design feature providing the structural support with minimal sight line interference. This mull post, with an extruded aluminum exterior cover, takes up only 3-1/16" of visual space from each direction.



Our most comprehensive door category, swing products are widely used for nearly every type of project including new construction, remodeling and light commercial. Swing doors are versatile, long-lasting and design friendly.

Configurations

- 1, 2, 3 and 4-wide
- French doors: 2, 3 and 4-wide
- Transoms: 1, 2, 3 and 4-wide
- Sidelites: 2 1/2", 3 3/8" & 4 13/16" Stiles
- Segment head:
 - 1 and 2-wide
 - French 2-wide
 - Quarter segment French sidelite
- Full Radius

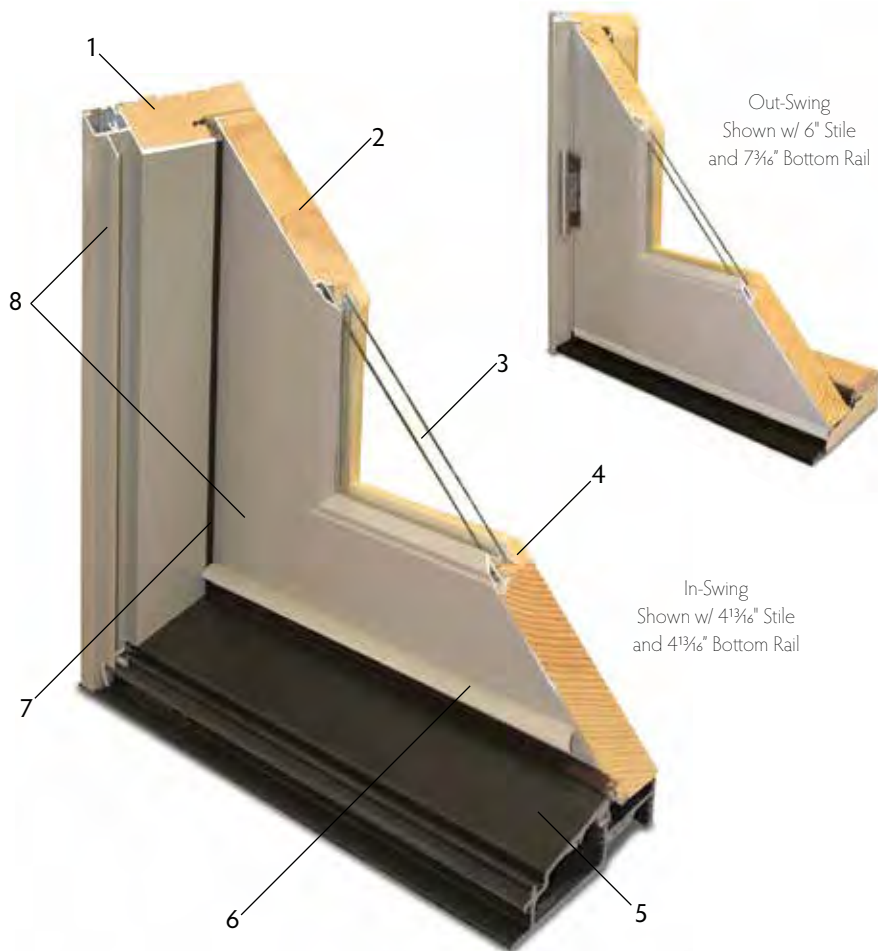

Out-Swing
Shown w/ 6" Stile
and 7 3/8" Bottom Rail

In-Swing
Shown w/ 4 13/16" Stile
and 4 13/16" Bottom Rail

	Specifications
Maximum RO Width	1 wide = 3' 7 7/8" -- 2 wide= 6' 2 7/8"
Maximum RO Height	9' 2 3/4"
Door Panel Thickness	1 3/4" thick panels
Stile Widths	3 3/8", 4 13/16" & 6"
Top Rail Heights	3 3/8", 4 13/16" & 6"
Bottom Rail Heights	4 13/16", 7 3/8" & 12"

1. 4 5/16" jamb.
2. 1 3/4" thick panels.
3. 3/4" tempered insulating glass.
4. Interior wood glazing bead.
5. .125 pultruded resin coated fiberglass sill.
6. Panel drip edge.
7. Full surround weatherstrip.
8. .050 extruded aluminum clad on sash and frame. Wood units have primed panels on the exterior with cPVC brickmould.



The 2 1/4" door program is the perfect complement and extension to Lincoln's significant swing door offering. Greater heights (up to 10' tall) are achieved with the 2 1/4" panel system including our optional Lifestyle door panel. 5-point locking hardware is standard.

Configurations

- 1 & 2 wide
- French doors: 2 wide
- Transoms: 1 & 2 wide
- Sidelites: 3 3/8" & 4 13/16" Stiles



	Specifications
Maximum RO Width	1 wide = 3' 7 7/8" -- 2 wide = 7' 2 1/2"
Maximum RO Height	10' 2 3/4"
Door Panel Thickness	2 1/4" thick panels
Stile Widths	3 3/8", 4 13/16" & 6"
Top Rail Heights	3 3/8", 4 13/16" & 6"
Bottom Rail Heights	4 13/16", 7 3/8" & 12"

1. 5 1/8" jamb.
2. 2 1/4" thick panels.
3. 3/4" tempered insulating glass & 1 3/8" Triple Pane.
4. Interior wood glazing bead.
5. .125 pultruded resin coated fiberglass sill.
6. Panel drip edge.
7. Full surround weatherstrip.
8. .050 extruded aluminum clad on sash and frame. Wood units have primed panels on the exterior with cPVC brickmould.

Options

Design flexibility and accommodating accurately describe Lincoln's swing patio doors. Three different size options for stiles, rails and mid-rails epitomize versatility with options to customize doors for any design aesthetic.

- Top Rail sizes: 3 3/8", 4 13/16", 6"
- Stile sizes: 3 3/8", 4 13/16", 6"
- Mid Rail sizes: 3 3/4", 4 3/4", 6 3/4"
- Bottom Rail sizes: 4 13/16", 7 3/16", 12"

These doors limit the limitations. Pick the door that's right for you from Lincoln and enjoy the possibilities.



Styles

In-Swing: Make a statement with Lincoln's most popular door product. In-swing doors blend with almost every architectural theme and they are incredibly stylish. Secure multipoint hardware makes a Lincoln in-swing door both beautiful and strong.

Adjustable hinges are standard (residential) and ball-bearing hinges (light commercial) are available. Easy operating color matched sliding screens feature extruded framing for superior strength.

Out-Swing: Lincoln out-swing door products are packed with performance. The harder the weather pushes against the operable panels, the tighter the weatherstrip seal on the frame becomes.

Also, by swinging to a building's exterior, this type of door will not create an interruption to your interior décor. Durable maple thresholds are standard. Optional ADA compliant (low profile) thermally broken sills are available.





French Doors

A French style swing patio doors' most distinguishable feature is its ability to have both panels operate. Lincoln offers extremely functional in-swing or out-swing models that can be used for large object passageways. An active panel operates as the primary operator and the passive panel need only be utilized when you want the entire use of the opening. French doors may also be configured with different panel widths. Offset panel sizes create an entrance style look with the functionality of a large net clear opening.

Our strong three-point hardware system looks great, locks securely and is available with either a handle activated bolt or center activated bolt (dummy handle optional). French doors are available in 2, 3 or 4-wide configurations.

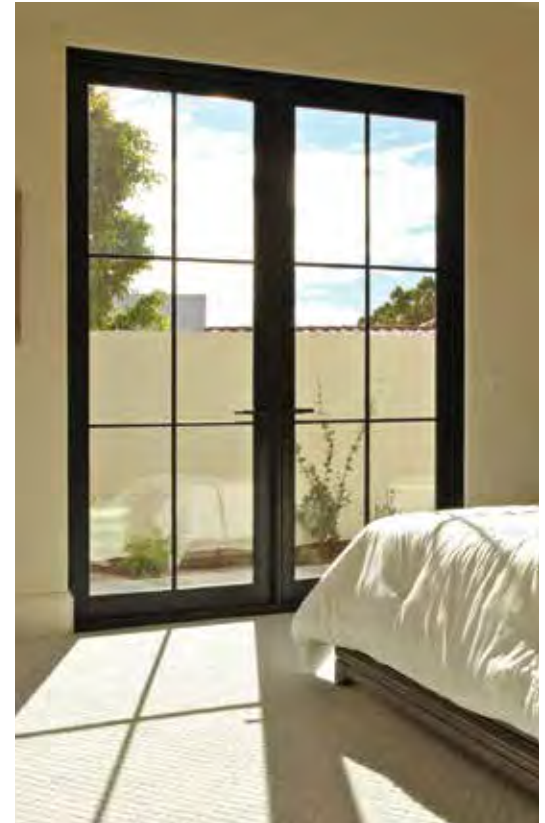

Segment Top

Enhance your home with a little curve appeal from Lincoln. By utilizing a segment top swing patio door in your design you incorporate a subtle accent that compliments almost any architectural theme.

The radius option, available in 6' radius only, can be used with both in-swing and out-swing patio doors. Select your radius top option for a single door or use it with our factory mulled side-lite combinations for a more dramatic statement.

Whether viewed from the curb or inside your home, the gentle slope of our radius doors have lasting design appeal.



Entry Sill

Lincoln's entry sill option resists weathering, keeps air and water out while providing long-lasting adjustability.

- Adjustable PVC rail with ImperiSeal continuous gasket
- Bronze contemporary exterior color
- Composite underlayment is durable, non-rot and thermally advanced
- In-swing doors with 4 1/8" or 6 1/8" jamb depth.
- Color matched door sweep



Quanex Sill
(Shown with Frame Screen Track Filler)

In-Swing Extended Jamb

Lincoln swing doors feature a 4 1/8" jamb depth that will accommodate an additional 2" clad extrusion to the exterior. Doors extended in this fashion will have full hinge travel on a 6 1/8" wall thickness. Additional interior wood jamb extensions are available for thicker walls.

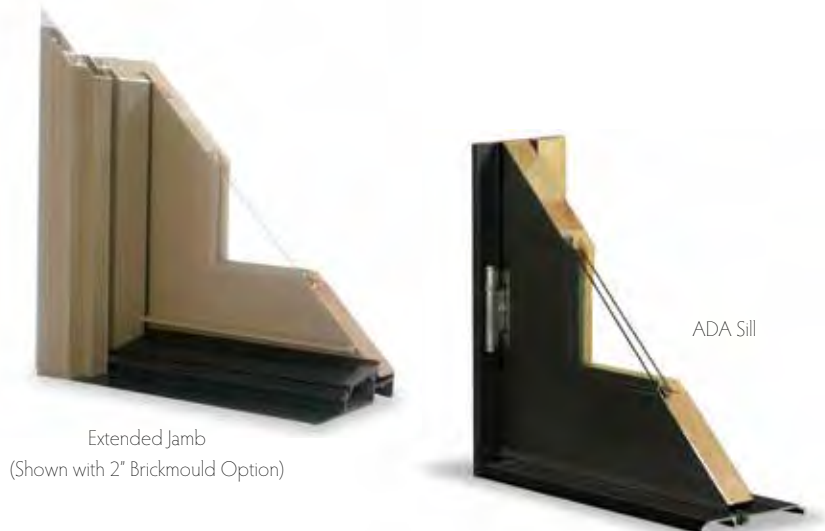

Extended Jamb
(Shown with 2" Brickmould Option)

ADA Sill

ADA Sill

Low profile sills are easily adaptable to our frame components making the Lincoln swing doors ADA code compliant and can be used in most light commercial applications.

ADA sills are constructed with extremely durable dark bronze anodized aluminum complete with a thermal break for better energy efficiency. This option is available in 4 1/8" and 6 1/8" jamb depth.



Mid-Rail & Wide Bottom Rail

Accessorize your swing doors by inserting an optional mid-rail. Rails run horizontally and can be located at virtually any height. Additional divisions are made by adding a vertical rail. The spaces created can be filled with raised panels, flat panels or insulated glass. Mid-rail sizes are 3 ¾", 4 ¾" and 6 ¾" and may be used together on the same panel.

Three bottom rail choices add versatility to swing patio door panels. The bottom rail options include nominal measurements of 4 13/16", 7 3/16" and 12". Choose one of the bottom rails with any door height and design a door panel best suited for your project. Commonly used on taller residential doors and in light commercial applications, our durable 12" bottom rail allows ample room for a kick plate.



Flat Panel & Raised Panel

With a mid-rail used horizontally and/or vertically, you can place panels at standard and custom height locations to further enhance the door design.

The stylish and architecturally friendly raised panel adds depth and feel to contemporary or traditional design themes. Raised door panels feature durable color-matched polane painted exteriors.

Flat panels are popular because of straight clean aesthetically pleasing lines. These panels are insulated with a painted extruded aluminum veneer exterior (Aluminum Clad) and thick stain-grade wood interiors.





Commercial Doors

Fitting your commons area or vestibule with Lincoln's diverse door offering allows for continuity in design with matching clad colors, glazing appearance, durability, delivery and performance all backed with a substantial warranty.

Our door products are stylish, functional (both in-swing or out-swing) and can be specified with nearly endless size options and design configurations.

ADA Sill

Some commercial applications require swing door thresholds that do not exceed $\frac{1}{2}$ " total height above finished floor height.

- Strategically located thermal break under door panel to reduce thermal transfer.
- Available on doors both at $4\frac{1}{16}$ " and $6\frac{1}{16}$ ". Interior extension jambs can be utilized for walls that vary.
- Bronze anodized finish.

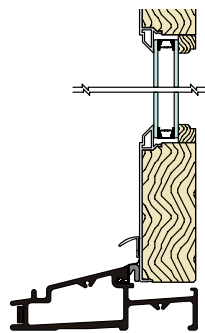

In-Swing Standard Sill

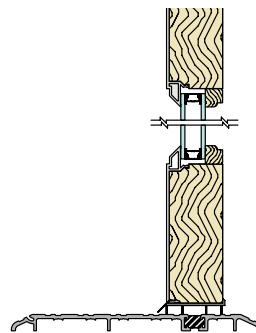

In-Swing ADA Sill

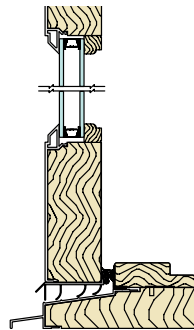

Out-Swing Standard Sill

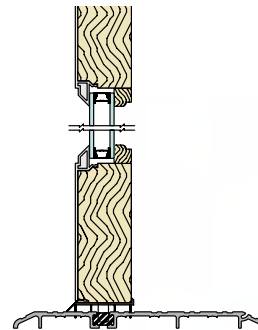

Out-Swing ADA Sill



Concealed Cable Prep and Panel Spacing

A concealed cable route can be specified for doors to eliminate unsightly rods.

The cable prep consists of a 3/4" x 3/4" continuous route profile hidden inside the door panel for use with VonDuprin (or similar) panic bar systems.

Double wide doors can be specified without an astragal with spacing between panels for your weatherstrip detail. Options include: 3/16", 1/4", 3/8", 1/2".

Panel Combinations

Lincoln door panel thickness of 1 3/4" and 2 1/4" & multiple stile and rail configuration will suit your building's style.

- Top Rail sizes: 3 3/8", 4 13/16", 6"
- Stile sizes: 3 3/8", 4 13/16", 6"
- Mid Rail sizes: 3 3/4", 4 3/4", 6 3/4"
- Bottom Rail sizes: 4 13/16", 7 3/16", 12"

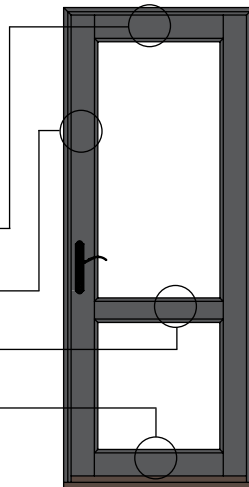

Ball Bearing Hinges

Optional 4" ball bearing hinge are available in 9 spectacular finishes.

Hinges feature a 5/8" radius corner and NRP (non-removable pins) for added security.



Pre-Finished White and Black Interiors

Take one thing off the general contractors' task list by finishing the interiors. Factory-applied painted interiors will save valuable time and money all while protecting the wood during the construction phase. Introduce your builder client to the peace of mind that a Lincoln factory finish provides.



Pre-Finish White



Pre-Finish Black



Hardware

Handles & Backplates: Our handles are manufactured using the finest quality brass alloys. The surface of the handle, except oil-rubbed, is protected by a transparent enamel finish which offers strength and durability as well as a smooth, blemish free surface. Oil-Rubbed has a “live” finish that changes over time. Celebrate your distinctive design style by creating a handle package from our many finish options, lever choices and backplate styles.

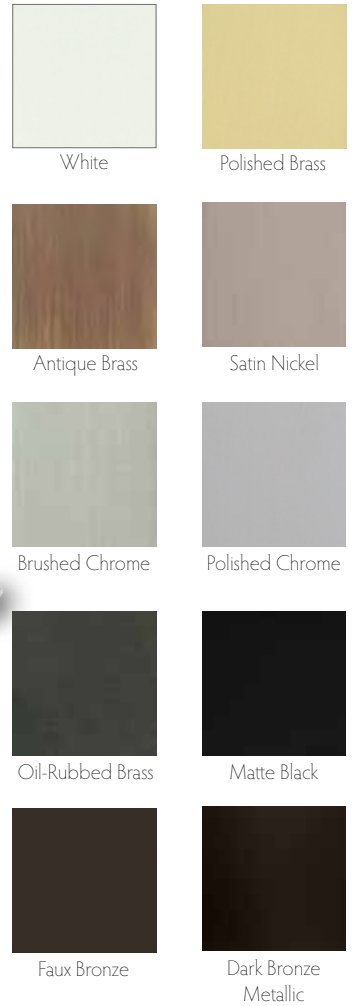
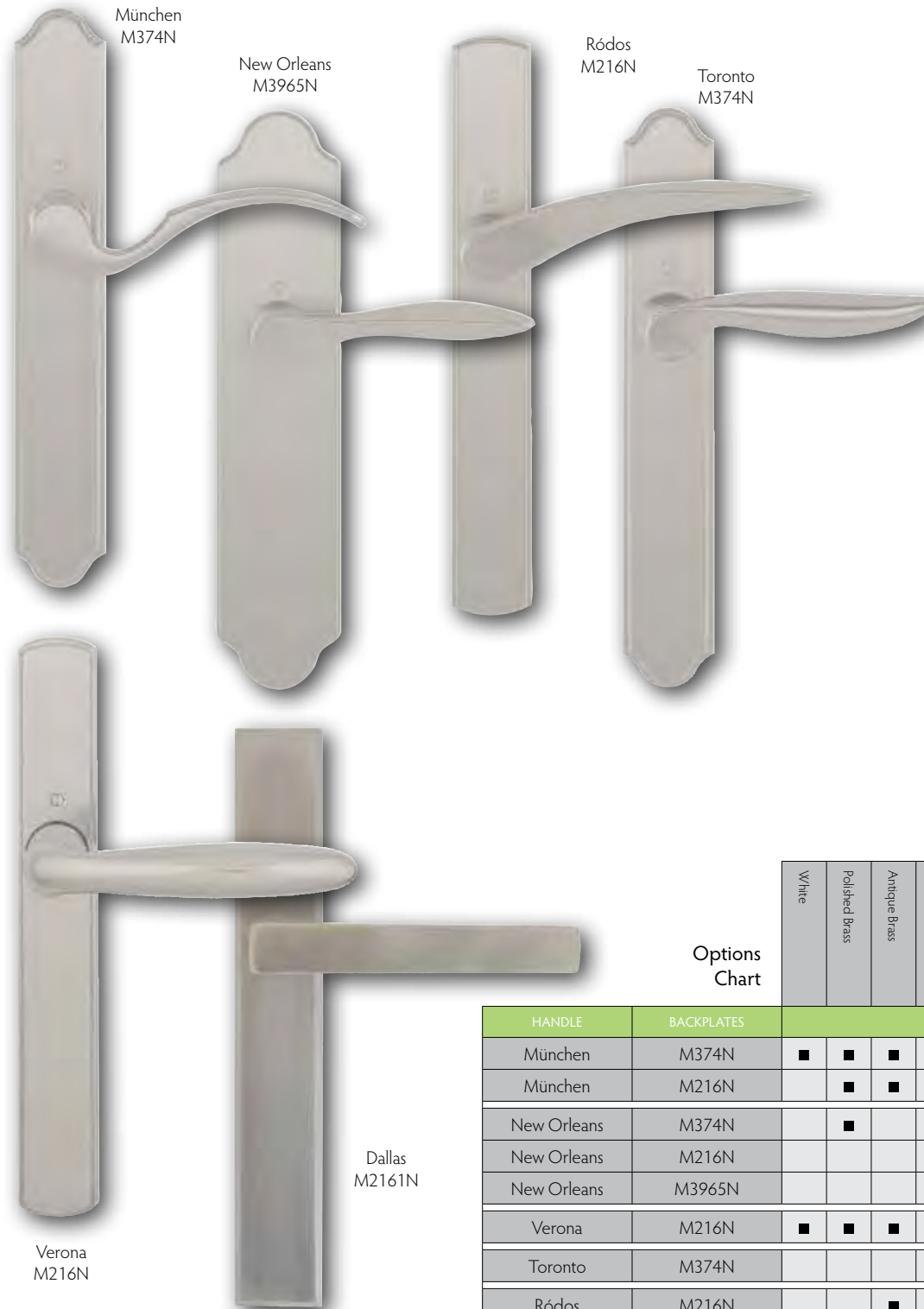

Options Chart

HANDLE	BACKPLATES	FINISHES									
		White	Polished Brass	Antique Brass	Brushed Chrome	Polished Chrome	Satin Nickel	Oil-Rubbed Brass	Faux Bronze	Matte Black	Dark Bronze Metallic
München	M374N	■	■	■	■	■	■	■	■	■	
München	M216N		■	■	■		■	■	■	■	
New Orleans	M374N		■				■		■	■	
New Orleans	M216N						■	■	■	■	
New Orleans	M3965N						■		■		
Verona	M216N	■	■	■	■	■	■	■	■	■	
Toronto	M374N				■		■	■	■	■	
Ródos	M216N			■	■		■		■	■	
Dallas	M2161N		■				■		■	■	■

3-Point & 5-Point Hardware: As standard, active door panels utilize our multi-point (3-Point or 5-Point) hardware system. Engaging the multi-point system creates a tight seal, maintains straight door panels and is an added security measure. Passive doors are equipped with either a handle activated bolt system or the flush bolt version firing rods securely into the head and sill.







Single Point Hardware: While specifying your next entry system, consider the Single Point Hardware mechanism for easier operation. This hardware is simple to operate as no handle activation is required to throw the deadbolt or engage other locking points. This system accepts the same trim hardware and can be keyed alike to match all your other Lincoln swing doors.



Hinges: In-swing doors are equipped with adjustable hinges including a secure non-removable pin to ensure safe and smooth operation. Adjustments are made via the large 3/16" hex head screw both vertically (Set Hinge) and horizontally (Guide Hinge).

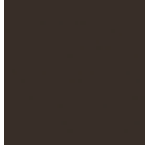
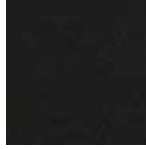

Standard Hinge Finishes

					
Polished Brass	Antique Brass	Brushed Chrome	Oil-Rubbed Brass		
					
Grey Powder Coat	White Powder Coat	Gold Powder Coat	Matte Black		
					
Satin Nickel	Antique Nickel	Faux Bronze	Bronze Anodized	Resista® Satin Nickel	Resista® Polished Brass

Distinctive rooms require an exceptional door system. Lincoln Folding doors, when completely opened, leave a stunning unobstructed view. Multiple configurations consist of stacking panels and may include an operable out-swing panel.

Configurations

Numerous out-swing configurations are available anywhere from one to eight panels in each direction and can include an access panel. The innovative hinge system enables all door panels to be made the same size regardless of the door configuration.

See examples of Lincoln's matching Folding Window at www.lincolnwindows.com.

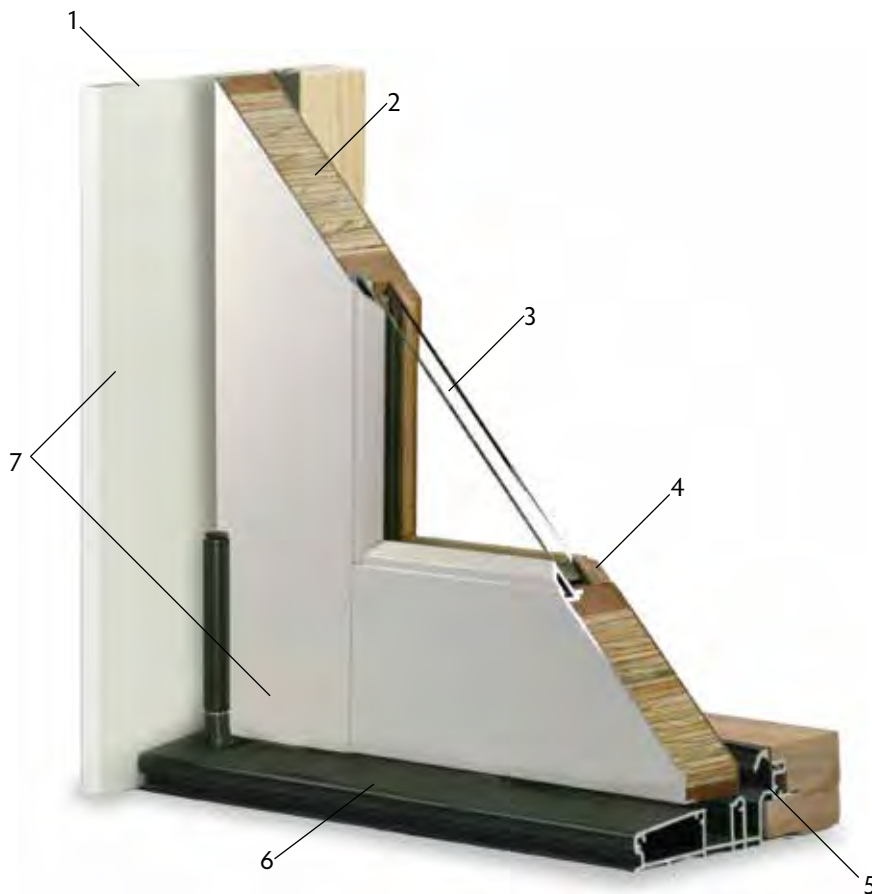

	1 3/4" Panel Thickness	2 1/4" Panel Thickness
Maximum Panel Width	3' 6"	3' 6"
Maximum Panel Height	9' 0"	10' 0"
Maximum Number of Panels	16 Panels	16 Panels
Approx. Maximum Width	48'	48'
Maximum Height	9' 4 3/4"	10' 4 3/4"

NOTE: When using maximum door width and height, door may exceed maximum door weight. Calculated weight check should be done.

1. 5 1/2" jamb with clad exterior. 6 1/16" jamb on primed exterior.
2. 1 3/4" & 2 1/4" thick panels.
3. 3/4" tempered insulating glass & 1 3/8" Triple Pane. (2 1/4" panels only)
4. Interior wood glazing bead.
5. Full surround weatherstrip.
6. .080 extruded aluminum sill (shown) or recessed floor channel guide option.
7. .050 extruded aluminum clad on panels and frame.

Hardware

Track, Guide Channel and Sill: The Folding patio door has a top mounted track system allowing the weight of door to be carried on the header. The bottom guide glides with minimal effort in a polypropylene floor channel lining allowing a smooth, almost silent rolling action. A low threshold guide channel is available for internal applications - no obtrusive door sill, just a recessed track in the floor.

Handles & Backplates: The main operating panel for the folding door system utilizes the same high quality HOPPE hardware found on all Lincoln swing patio doors. The benefits include: matching styles, color continuity and the keyed alike feature.

Pull Handles, Hinges and Twinpoint: The remaining panels in the folding door system are operated using heavy-duty pull handles and hinges. Three hinges come standard with each Door panel - with a fourth hinge added for doors over 7'4". The twinpoint lever activates concealed rods into the head and sill for secure locking action.

Screens

All screens are made-to-order and specially configured for each bi-fold door system. They are available for openings up to 24' wide x 10' high and feature load balancing technology for effortless operation while remaining firmly in any chosen position until further pressure is applied. Screens store easily into its own frame when a clear opening is desired.

The tough PVC-coated polyester mesh used in the screen is hard wearing, resistant to damage, easy to clean and can be replaced if necessary. Choose a single function or double functioning system where six mesh options are available.



Screen Mesh
Options

SLIDE PATIO DOORS

Featuring wide, lifestyle or narrow styles, our slide doors are a beautiful combination of practicality and performance. Light up your room and keep the weather outside all while avoiding the clearance needed with a swinging patio door.

Configurations

- 3 Stile Widths: 2 1/2", 3 3/8" & 4 13/16"
- 2-wide
- 3-wide
- 4-wide (OXXO)
- Transoms: 1, 2, 3 and 4-wide
- Sidelites



1. 4 1/16" jamb.
2. 1 3/4" thick panels.
3. 3/4" tempered insulating glass.
4. Interior wood glazing bead.
5. .022 stainless steel roller track cover.
6. .125 pultruded resin coated bronze fiberglass sill.
7. .050 extruded aluminum clad on panels and frame. Wood units have primed panels on the exterior with cPVC brickmould.
8. Integral screen channel.
9. "t-Rail" Panel Guide System.



Standard Sill



High Performance Sill

Hardware

Rollers & Handles: Slide patio doors feature a dual lock and keeper system with an optional keyed lock. This 2-point hardware securely engages the heavy-duty keeper by latching both upward and downward. Door panels glide easily on durable ball-bearing rollers.



Allure Handleset (standard): Both functional and attractive, with its painted metal available in five popular finishes. Keyed cylinders are optional.

Signature Handleset: Available in twelve finishes. If there is more than one door on a project, they may be ordered keyed alike. The latch mechanism is dual point, latching both up and down to resist forced entry by lifting the panel. Keyed cylinders are standard.

Contempo Handleset: Building and completing a contemporary or modern design theme off requires the straight sleek lines of the Contempo handle set. The shape and color options pair nicely with the Dallas Hardware found on our swing doors creating the perfect room accent. Keyed cylinders are standard. Available in nine finishes.

Flush Pull Hardware: While large pull handles do add leverage, sometimes they are difficult to design around. Flush Pull hardware has exactly the minimal interior exposure some interior décor's call for. Available in three finishes.

Finish Options	Contempo												
	White	Adobe	Sandstone	Polished Brass	Faux Bronze	Oil-Rubbed Brass	Antique Brass	Brushed Chrome	Polished Chrome	Antique Nickel	Satin Nickel	Matte Black	Matte Black
Allure	■	■	■		■								■
Signature	■	■	■	■	■	■	■	■	■	■	■	■	
Contempo	■			■	■	■	■	■			■	■	
Flush Pull											■	■	■

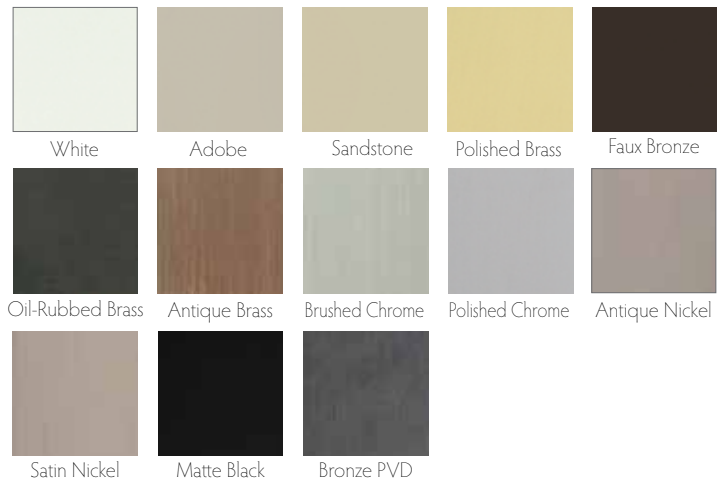

Stile Options

Slide doors continue to be a popular design for tighter spaces and are minimally invasive because an open panel simply covers the fixed portion. Looking for a lot of glass, choose from 2 narrow stile options; 2 1/2" and 3 3/8". These traditional sliding patio doors provide the most visible glass of all our door products. No room for a swinging door? Then compliment your home with an elegant wide 4 13/16" stile slide door from Lincoln. Our wide stiles feature more wood than a traditional slide door and become the perfect choice when using an alternate wood species.

Screens

Sliding patio door screens offer a heavy-duty extruded frame channel available in all our aluminum clad colors. There are adjustable rollers on top and bottom. Screen mesh options include BetterVue, UltraVue and aluminum.

Lincoln's multi-slide patio door is an extremely versatile system designed where immense areas of glass are desirable. A closed door will highlight elegant wide-stile panels or emphasize thin sight lines when using our narrow stile options.

Configurations

We offer numerous stacking or pocketing configurations from one panel to ten, creating a superb range of door widths and heights.

** It is highly recommended that the Multi Slide Door is installed in areas with a minimum 8' overhang to prevent water or air infiltration.*

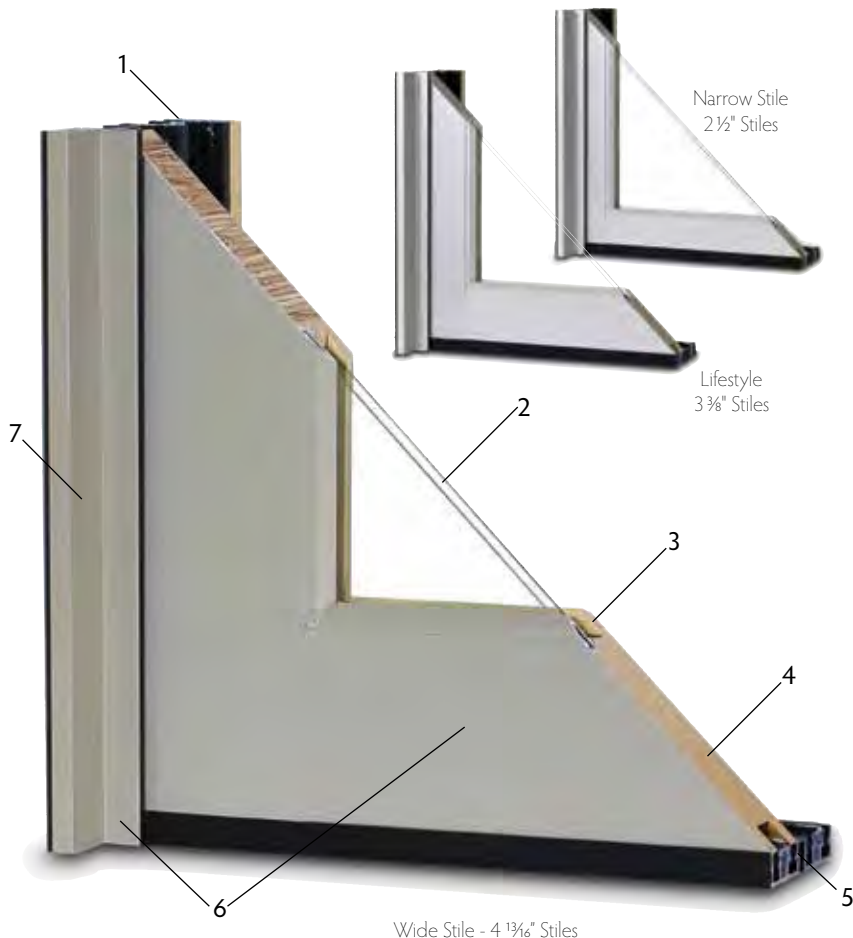

Specifications

	1 3/4" Panel Thickness	2 1/4" Panel Thickness
Maximum Panel Width	4' 1/2"	6' 0"
Maximum Panel Height	9' 0"	10' 0"
Maximum Number of Panels	10 Panels	10 Panels
Approx. Maximum Width	38'	38'
Maximum Height	9' 3/8"	10' 3 1/8"
Stile Options	2 1/2", 3 3/8", 4 13/16"	3 3/8", 4 13/16"
Minimum Roof Overhang	8' 0"	8' 0"

1. Modular frame system.
2. 3/4" tempered insulating glass. 1 3/8" triple pane optional with 2 1/4" thick panels.
3. Interior wood glazing bead.
4. 1 3/4" thick panels. 2 1/4" thick panels optional.
5. Thermally-broken bronze anodized sill.
6. .050 extruded aluminum on panels and frame.
7. Frame width accommodates from 1 to 10 panels.



Our Lift & Slide is truly elegant, architecturally driven and entirely functional. Modern building systems allow for massive openings and Lincoln's ability to utilize panels up to 5' by 10' fits this design criteria perfectly. Operational concerns? No problem! The 'lift' system elevates the panel for simple, easy 'slide' action. Walls of patio doors will disappear leaving the extraordinary uninterrupted view you long for.

Configurations

- Pocketing
- Stacking
- 90° Corner/Inverse 90°
- One Way Direction
- Bi-Parting

Panel Options

Lincoln multi-slide doors systems feature 1 3/4" or 2 1/4" thick panels, perfect for your next building project whether its modern, contemporary or traditional appearing. Capture your spectacular view with just the right panel choice, door size and operational function.

- **Narrow Stile:** 2 1/2" Wide - 1 3/4" thick Only
- **Lifestyle Stile:** 3 3/8" Wide - 1 3/4" or 2 1/4" thick
- **Wide Stile:** 4 13/16" Wide - 1 3/4" or 2 1/4" thick

Operational Choices

Stacking: The stacking system allows all operating panels to fit over the end stationary panel. Door jamb widths will vary with the number of panels/tracks utilized. A pull handle is commonly used with this door for an additional design element.

Pocketing: Doors disappear fully into a specially designed wall cavity. A pocketing arrangement employs a flush lock permitting the locking panel to completely slide out-of-sight. What remains is an entirely open space.

Bi-Parting: Operating panels oppose to operate and join in the center with an astragal.

	Specifications
Maximum Panel Width	6' 0"
Maximum Panel Height	10' 0"
Minimum Panel Width	2' 0"
Maximum Number of Panels	10 Panels
Minimum Number of Panels	1
Door Panel Thickness	2 1/4"

Multi-Slide Hardware

Two styles of lever pull handlesets are available for multi-slide stacking door configurations. The multi-slide comes standard with a stainless steel 2-point locking mechanism built for lasting appearance and performance. The adjustable rollers glide easily, quietly and are available in stainless steel.



Our multi-slide patio doors are manufactured with Hoppe two point locking system.

Flush Pull Hardware

The attractive flush pull handles, designed to allow the panels to recess fully for pocketed multi-slide systems, can also be used for the stacking panel configurations when minimal hardware is desired. The flush pulls comes standard with the same 2-point locking gear utilized by the lever pull option.

Also available with Lincoln Standard Slide Patio Door with 3 3/8" & 4 1/8" stiles.



Lift-&-Slide Hardware

Operate these magnificent doors by turning the solid brass lever handle 180 degrees to 'lift' the panel easily up off of the sill track and on to the corrosion resistant carrier hardware. The 'slide' operation is smooth as the glass reinforced nylon rollers glide on a stainless steel track cap. Stacking doors feature non-removable hardware standard and pocketing doors use removable hardware as standard.



Satin Nickel



Faux Bronze

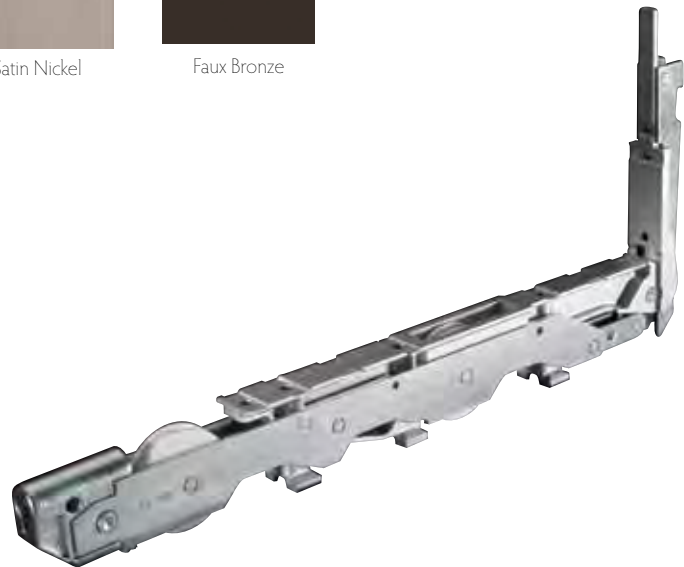

Carrier Bogie Wheel System

Sill Options

Three distinctive low profile sill options are available for the Multi-Slide and Lift & Slide doors and they accommodate nearly any flooring condition. The full width sill has an inside riser and a nosing system running the complete length of the door unit. The staggered track system features a flat edge, creating a smooth transition to floor coverings. A weep system is available. Lincoln's 'T' track allows for a flooring detail between the track system minimizing the visible track area.

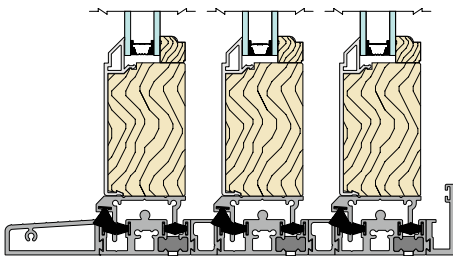

Full Sill w/ Nosing & Riser
Multi-Slide with 1-3/4" Panels

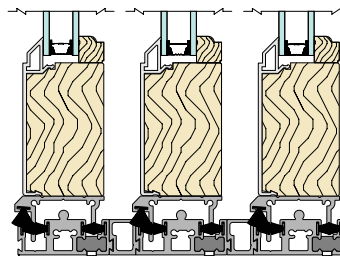

Stagger Sill - Low Profile
Multi-Slide with 1-3/4" Panels

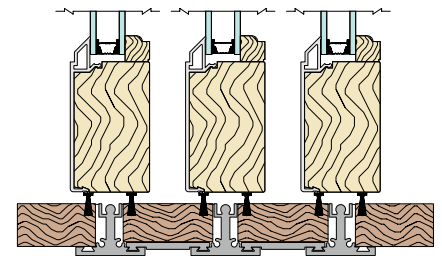

T-Track Sill
Multi-Slide with 1-3/4" Panels



Revitalize

REPLACEMENT WINDOWS & PATIO DOORS

OUT WITH THE OLD AND IN WITH THE NEW!

Do you live with any or all of the following: (1) high energy bills due to heat loss in the winter and heat gain in the summer, (2) fogging glass or water damage caused by condensation, (3) chipping paint or rotting wood, (4) difficulties with opening and cleaning, (5) excessive air and noise penetration, (6) fading window coverings, carpet and upholstery? You don't have to!

Over the years, windows and patio doors can become worn from continual use and exposure to the elements. In addition to being hard to operate and looking unattractive, they are not usually energy efficient. By simply replacing old windows and patio doors, you can easily eliminate these problems and increase the energy efficiency, comfort, appearance and value of your home - all in record time with little or no inconvenience to daily living.

Whether your remodeling project consists of replacing a few windows, adding on a room, bringing your home up to code or making historical renovations, we have the product that will meet your exacting specifications. Revitalize your home!

CALL: 800.967.2461



Take your old, drafty, hard to operate, inefficient windows and update them with all of today's technology and styles. Over the years, the sash, balance systems and hardware of a window may wear out, while the trim and frame can remain in good condition. Lincoln makes updating these windows a snap by offering three replacement window options, the Lincoln Fit double hung, Lincoln Fit casement and the Double Hung Replacement Kit. You can easily increase the energy efficiency, comfort, appearance and value of your windows in record time with little or no inconvenience to daily living.



Lincoln Fit Insert Windows

Window replacement doesn't have to mean ripping out the old window and damaging drywall. The Lincoln Fit is designed to be installed from the interior or exterior of the home with minimal disruption to the existing frame and trim. Every Lincoln Fit is custom sized to your exact specifications, ensuring a perfect fit for your window opening. This versatile product is available for double hung, casement, transom and picture window replacements.

Double Hung Replacement Kit

Even huge jobs become small projects with the Double Hung Replacement Kit. There is no reason to replace or even disturb the interior or exterior trim. The replacement kit utilizes the existing window frame in combination with snap-in jamb liners and energy efficient sash. Since we offer custom sizing, finding the right size replacement for your project is easy.









When only the best will do.

Choose Lincoln for your new construction, remodeling or even light commercial projects. With almost 75 years of manufacturing experience built into every unit, we engineer our windows and patio doors for visual appeal as well as outstanding performance. In addition, Lincoln backs it up with exceptional customer service before and after the sale.

We are continually expanding our list of products, options and accessories. Check us out online for the latest offerings in the building industry. We are confident that we have the perfect windows and patio doors to harmonize with your ideas and designs.



Lincoln Wood Products, Inc.
 1400 W. Taylor Street • P.O. Box 375
 Merrill, Wisconsin 54452-1355
 800-967-2461 • Fax: 715-536-9783
www.lincolnwindows.com



Learn more about our products and options by contacting a local authorized Lincoln dealer or visiting us online at lincolnwindows.com.



Committed to protecting and preserving the environment.

Lincoln Windows is committed to environmental stewardship. As responsible corporate citizens, we are dedicated to manufacturing energy efficient products and managing our resources in a manner that reduces our impact on the environment.



Lincoln Windows is an ENERGY STAR® Partner.



Many of our products carry certification by the National Fenestration Rating Council (NFRC).



Lincoln products carry an extensive warranty. Ask your dealer for complete information.



Lincoln Windows & Patio Doors proudly supports the American Institute of Architects (AIA) Continuing Education System (CES).